

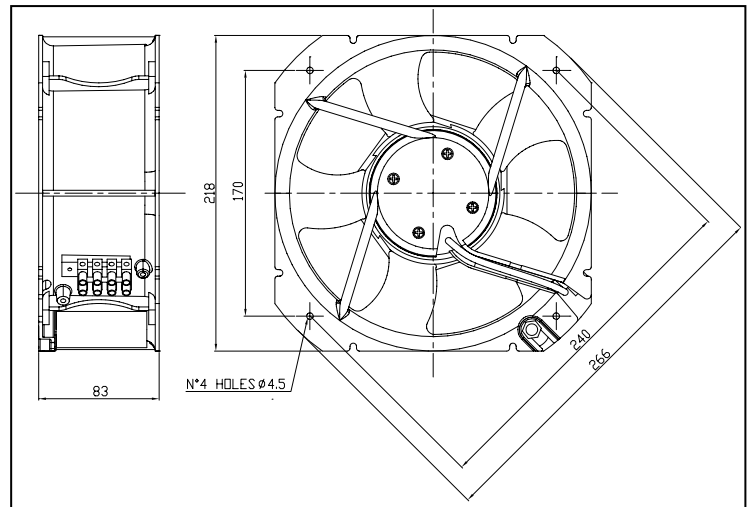

**DRAWING**



**FEATURES**

- Fan casing of aluminium alloy die casting and impeller of metal.
- Capacitor run external rotor thermally protected against running overload.
- Electrical connection via terminal block 3 pins (L-N-PE).  
No 2 holes for M4 thread on the casing for earth connection.
- Rated temperature range:  
Ball bearing from -40°C to +70°C
- Service life L10:  
Ball bearing 40,000 hours at 40°C  
20,000 hours at t max
- Weight 2395g.

**AIR FLOW CURVES**

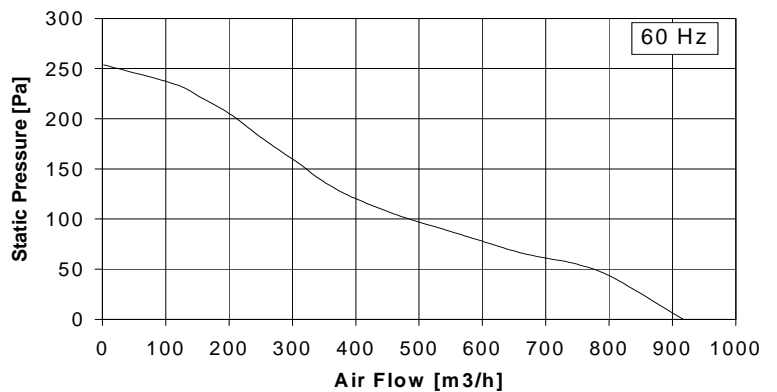
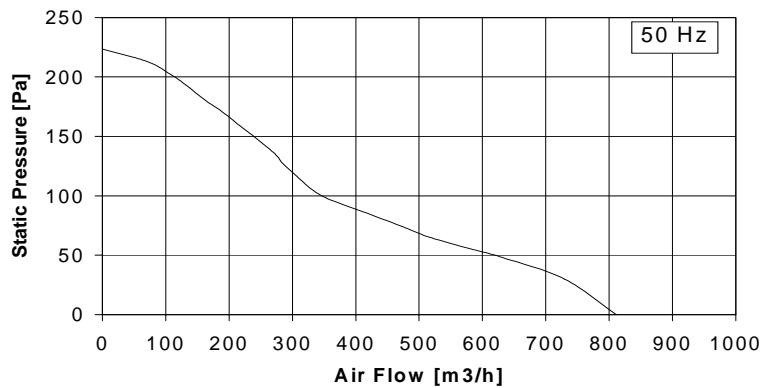

Please refer to our terms of sales including our warranty and limited liabilities clauses.

Model	Rated Voltage [V]	Frequency [Hz]	Input Power [W]	Speed [rpm]	Air Flow [m3/h]	Static Pressure [Pa]	Noise [dB(A)]	Approvals		
								UL	CUL	VDE
C22S12HKBE00	115	50/60	71/122	2770/3120	812/917	224/254	63/65			
C22S23HKBE00	230	50/60	67/115	2770/3120	812/917	224/254	63/65			