

# INDUCTIVE ATEX SENSORS

- AXM** = cylindrical amplified a.c. + d.c. 2-wire 10 ÷ 50 V
- DC** = cylindrical NOT amplified d.c. NAMUR series
- DCA** = cylindrical amplified d.c.
- DCE** = cylindrical extended sensing distance d.c. series
- DCL** = cylindrical analogue linear output
- DF** = slot sensors NOT amplified d.c. NAMUR series
- DSA** = cylindrical amplified d.c. SHORT series
- DSE** = cylindrical amplified extended sensing distance d.c. SHORT series

Diameter of cylindrical sensor or slot width for slot types.  
For other types, change the number with the following:

- 80** = diameter 80 mm
- P** = rectangular plastic 5 positions head 40 x 40 x 112
- R** = rectangular plastic with adjustable sensing distance 100 x 111 x 30
- T** = rectangular plastic 25 x 40 x 12
- X** = rectangular plastic 25 x 50 x 10
- Y** = rectangular plastic 30 x 50 x 15
- Z** = rectangular plastic 16 x 28 x 10

**P** = plastic housing sensor

- 4** = flush mounting
- 5** = non flush mounting

<b>DC</b>	<b>18</b>	<b>P/</b>	<b>4</b>	<b>6</b>	<b>0</b>	<b>9</b>	<b>KS</b>	<b>A</b>	<b>-5</b>	<b>PR</b>
-----------	-----------	-----------	----------	----------	----------	----------	-----------	----------	-----------	-----------

- 3** = with connector M12 x 1
- 6** = standard type cable output
- 7** = cable output with sheath support
- 8** = with gland
- A** = body length 50 mm completely threaded
- H** = male connector wired to the sensor (see page F-1)

- 0** = NO output (models with LED) or NC (models without LED)
- 1** = NC (normally closed output)
- 2** = NO + NC (complementary outputs)
- C** = NC (output normally closed on pin 2 of connector)

- 0** = NAMUR series 2-wire
- 8** = NPN
- 9** = PNP

- L** = smooth body
- K** = protection against short circuit and overload
- S** = LED output status
- T** = high temperature version

- A** = category 1G - 1D - NAMUR Series - Mode of protection "ia": to be used with associated apparatus
- MA** = category 1G - 1D - Amplified Series - Mode of protection "m"
- MB** = category 2G - 2D - Amplified Series - Mode of protection "m"
- 3GD** = category 3G - 3D - Amplified Series - Mode of protection "n" and "t"

Cable length (if required different than standard 2m)

For Polyurethane cable add PR



**NAMUR SERIES - diameters 4 - 5 - 6,5 - 8 mm •**  
**ATEX certified II 1GD for zone 0;20 •**  
**Cable output •**

**Housing A**

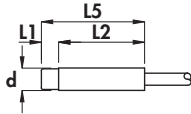

**Housing B**

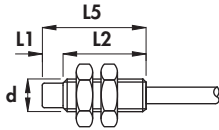

**Typical curve**

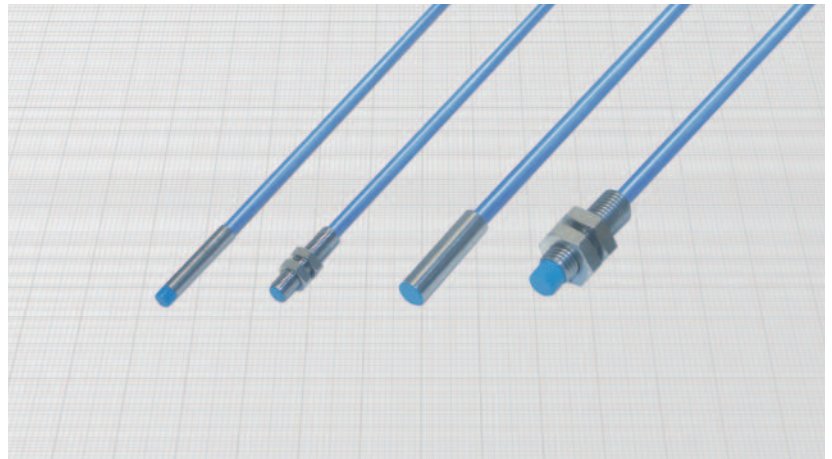
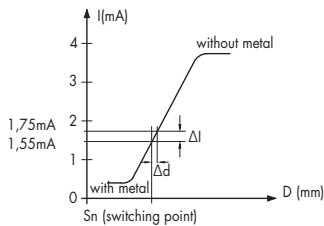

Diameter	M5 x 0,5	M8 x 1
Nut	Size	SW7
	Thickness mm	2,5
Max tightening torque Nm	2	10

**Materials:**

- Cable: 2 m PVC CEI 20-22 II; 90°C; 300 V;O.R.
- Housing: stainless steel
- Sensing face: plastic

**Technical data:**

- Supply voltage according NAMUR: 7,7 ÷ 9 Vdc
- Max ripple: 10%
- Consumption at 8,2 V with Rx = 1000 Ω
  - with metal: ≤ 1 mA
  - without metal: ≥ 3 mA
- Temperature range: -20° ÷ + 60°C
- Max thermal drift of sensing distance S<sub>f</sub>: ± 10%
- Repeat accuracy (R): 2%
- Degree of protection according EN60529: IP67
- Cable conductor cross section: 0,14 mm<sup>2</sup> in diameters 4 and 5 mm, 0,35 mm<sup>2</sup> in diameter 6,5
- Marking: II 1D Ex iaD 20 T80°C, II 1G Ex ia IIC T6
- Certified IMQ 08 ATEX 011 X
- Electromagnetic compatibility (EMC) according to EN60947-5-2
- According to: EN60947-5-6/EN60079-0/EN60079-11/EN60079-26
- Shock and vibration resistance according to EN60068-2-27/EN60068-2-6

**Safety parameters:**

- Vi max: 13,5 V
- Ii max: 60 mA
- Ci max: 100 nF
- Li max: 100 µH
- Pi max: 200 mW

**These sensors must be used in conjunction with associated apparatus (See Sect. E)**

**Use in hazardous area according to instruction manuals**

Housing	Mounting Flush mounting Non flush mounting	L1	L2	L3	L4	L5	Cable diameter	Body diameter (d)	Max switching frequency (f)	Nominal sensing distance (S <sub>n</sub> ) ± 10%	ORDERING REFERENCES 
		mm	mm	mm	mm	mm					
A	•	-	20	-	-	20	3	4	5	0,8	DC4/4600LA
B	•	-	20	-	-	20	3	M5 x 0,5	5	0,8	DC5/4700A
A	•	-	25	-	-	25	4	6,5	5	1,5	DC6,5/4700LA
A	•	5	20	-	-	25	4	6,5	3	2,5	DC6,5/5700LA
B	•	-	25	-	-	25	4	M8 x 1	5	1,5	DC8/4700A
B	•	5	20	-	-	25	4	M8 x 1	3	2,5	DC8/5700A

# CYLINDRICAL INDUCTIVE ATEX SENSORS IN METAL HOUSING

- **NAMUR SERIES** diameters 12 - 18 mm
- **ATEX certified II 1GD for zone 0;20**
- Cable output



## Housing B

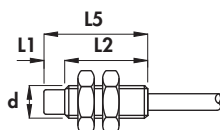

## Housing F-1

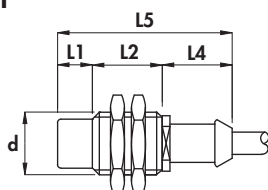

## Typical curve

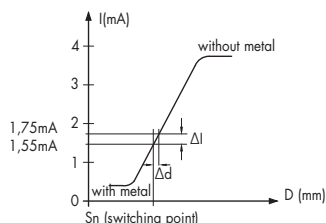

Diameter	M12 x 1	M18 x 1	
Nut	Size	SW17	SW24
	Thickness mm	4	4
Max tightening torque Nm	15	35	

## Materials:

- Cable: 2 m PVC CEI 20-22 II; 90°C; 300 V; O.R.
- Housing: nickel plated brass
- Sensing face: plastic

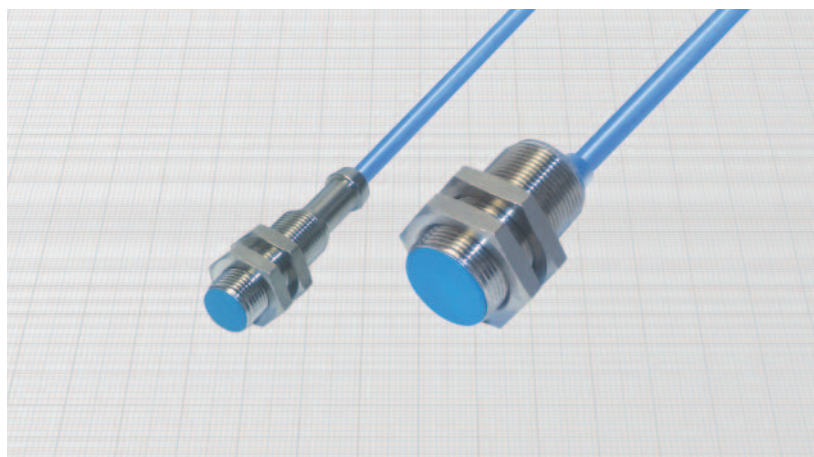

## Technical data:

- Supply voltage according NAMUR: 7,7 ÷ 9 Vdc
- Max ripple: 10%
- Consumption at 8,2 V with  $R_x = 1000 \Omega$ 
  - with metal:  $\leq 1 \text{ mA}$
  - without metal:  $\geq 3 \text{ mA}$
- Temperature range:  $-20^\circ \div +60^\circ \text{C}$
- Max thermal drift of sensing distance  $S_p$ :  $\pm 10\%$
- Repeat accuracy (R): 2%
- Degree of protection according EN60529: IP67
- Cable conductor cross section:
  - 0,35 mm<sup>2</sup> in diameter 12 mm
  - 0,75 mm<sup>2</sup> in diameter 18 mm
- Marking: II 1D Ex iaD 20 T80°C  
II 1G Ex ia IIC T6
- Certified IMQ 08 ATEX 010
- Electromagnetic compatibility (EMC) according to EN60947-5-2
- According to: EN60947-5-6/EN60079-0/EN60079-11/EN60079-26
- Shock and vibration resistance according to EN60068-2-27/EN60068-2-6

## Safety parameters:

- $V_i$  max: 13,5 V
- $I_i$  max: 60 mA
- $C_i$  max: 100 nF
- $L_i$  max: 100  $\mu\text{H}$
- $P_i$  max: 200 mW

**These sensors must be used in conjunction with associated apparatus (See Sect. E)**

**Use in hazardous area according to instruction manuals**

Housing	Flush mounting Non flush mounting	L1	L2	L3	L4	L5	Cable diameter	Body diameter (d)	Max switching frequency (f)	Nominal sensing distance ( $S_n$ ) $\pm 10\%$	ORDERING REFERENCES
		mm	mm	mm	mm	mm					
B	•	-	30	-	-	30	4	M12 x 1	5	2	DC12/4600A DC12/4700A DC12/5600A DC12/5700A
F-1	•	-	30	-	20	50	4	M12 x 1	5	2	
B	•	7	23	-	-	30	4	M12 x 1	1	4	
F-1	•	7	23	-	20	50	4	M12 x 1	1	4	
B	•	-	30	-	-	30	5	M18 x 1	1	5	DC18/4600A DC18/4700A DC18/5600A DC18/5700A
F-1	•	-	30	-	20	50	5	M18 x 1	1	5	
B	•	10	20	-	-	30	5	M18 x 1	0,5	8	
F-1	•	10	20	-	20	50	5	M18 x 1	0,5	8	

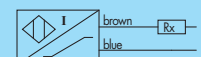



**NAMUR SERIES diameters 30 - 45 mm •**  
**ATEX certified II 1GD for zone 0;20 •**  
**Cable output •**

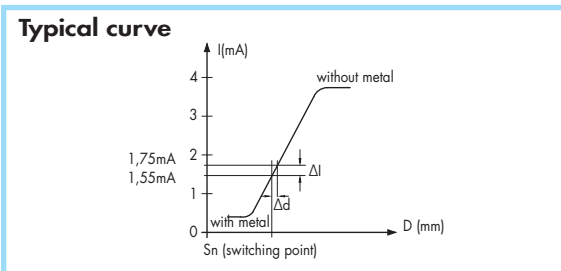
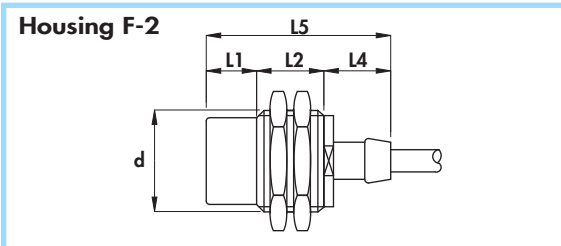
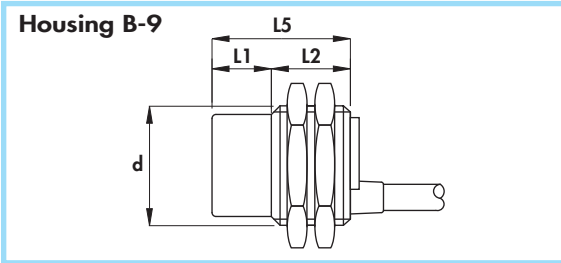

Diameter	M30 x 1,5	M45 x 1,5
Nut	Size	SW36
	Thickness mm	5
Max tightening torque Nm	80	70

**Materials:**

- Cable: 2 m PVC CEI 20-22 II; 90°C; 300 V; O.R.
- Housing: nickel plated brass
- Sensing face: plastic

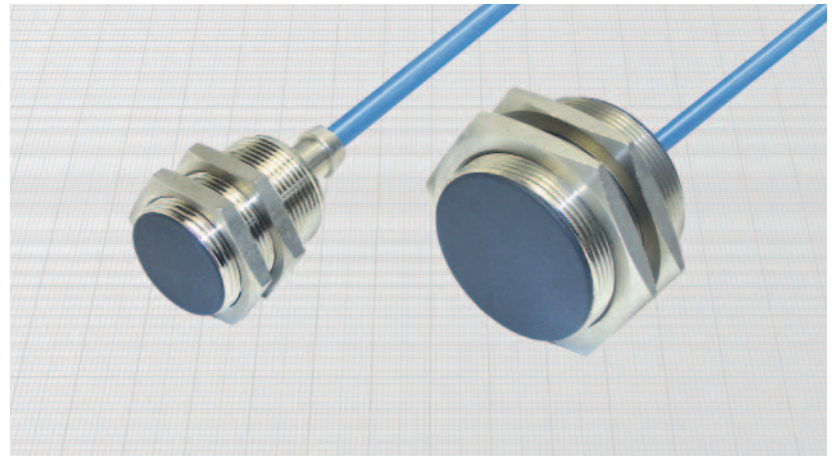

**Technical data:**

- Supply voltage according NAMUR: 7,7 ÷ 9 Vdc 10%
- Max ripple: ≤ 1 mA ≥ 3 mA
- Consumption at 8,2 V with Rx = 1000 Ω  
 with metal: -20° ÷ +60°C ± 10%  
 without metal: 2%
- Temperature range: IP67
- Max thermal drift of sensing distance S<sub>i</sub>: 0,75 mm<sup>2</sup>
- Repeat accuracy (R):
- Degree of protection according EN60529:
- Cable conductor cross section:
- Marking: II 1D Ex iaD 20 T80°C  
 II 1G Ex ia IIC T6
- Certified IMQ 08 ATEX 010
- Electromagnetic compatibility (EMC) according to EN60947-5-2
- According to: EN60947-5-6/EN60079-0/EN60079-11/EN60079-26
- Shock and vibration resistance according to EN60068-2-27/EN60068-2-6

**Safety parameters:**

- Vi max: 13,5 V
- Ii max: 60 mA
- Ci max: 100 nF
- Li max: 100 µH
- Pi max: 200 mW

**These sensors must be used in conjunction with associated apparatus (See Sect. E)**

**Use in hazardous area according to instruction manuals**

Housing	Flush mounting Non flush mounting	L1	L2	L3	L4	L5	Cable diameter	Body diameter (d)	Max switching frequency (f)	Nominal sensing distance (S <sub>i</sub> ) ± 10%	ORDERING REFERENCES
		mm	mm	mm	mm	mm					
B-9	•	-	35	-	-	35	5	M30 x 1,5	0,3	10	 <b>DC30/4600A</b> <b>DC30/4700A</b> <b>DC30/5600A</b> <b>DC30/5700A</b>
F-2	•	-	35	-	20	55	5	M30 x 1,5	0,3	10	
B-9	•	15	20	-	-	35	5	M30 x 1,5	0,2	15	
F-2	•	15	20	-	20	55	5	M30 x 1,5	0,2	15	
B-9	•	-	35	-	-	35	5	M45 x 1,5	0,3	20	<b>DC45/4700A</b>

# CYLINDRICAL INDUCTIVE ATEX SENSORS IN METAL HOUSING

- NAMUR SERIES WITH LED diameter 8 mm
- ATEX certified II 1GD for zone 0;20
- Cable output



## Housing B

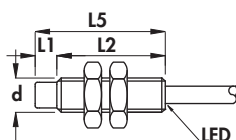

Diameter	M8 x 1	
Nut	Size	SW13
	Thickness mm	4
Max tightening torque Nm	10	

### Materials:

- Cable: 2 m PVC CEI 20-22 II; 90°C; 300 V; O.R.
- Housing: stainless steel
- Sensing face: plastic

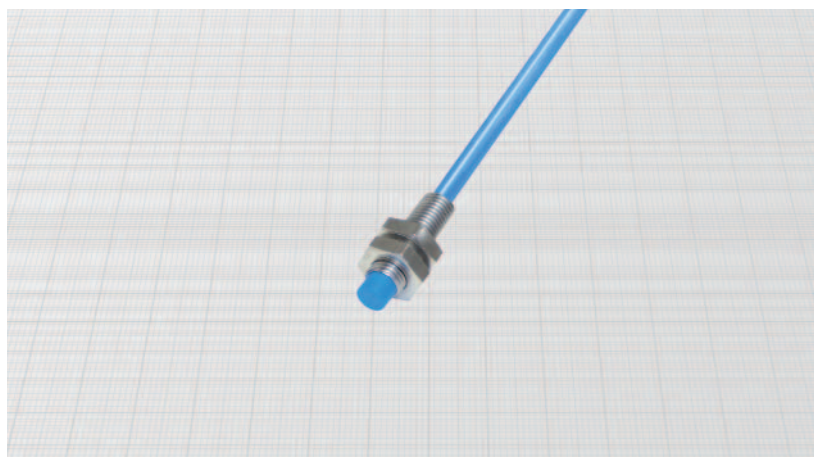

### General features:

With this new series of sensors it's possible to drive specific inputs for NAMUR sensors or inputs for 2 wires amplified switches with low current (up to 10 mA). The load can be applied on both terminals (function PNP or NPN). The output is internally triggered and monitored by LED.

### Technical data:

- Working voltage: 7,7 ÷ 9 Vdc
- Max ripple: 10%
- Off-state current ( $I_o$ ): ≤ 1 mA
- Minimum operational current ( $I_m$ ): 2 mA
- Rated operational current ( $I_p$ ): 10 mA
- Voltage drop ( $U_d$ ) with load 10 mA: < 6,5 V
- Voltage drop ( $U_d$ ) with load 8 mA: < 5 V
- Temperature range: - 20° ÷ +60°C
- Max thermal drift of sensing distance  $S_p$ : ± 10%
- Repeat accuracy (R): 2%
- Switching hysteresis max (H): 10%
- Degree of protection: IP67
- Switch status indicator: yellow LED
- Cable conductor cross section: 0,35 mm<sup>2</sup>
- Marking: II 1D Ex iaD 20 T80°C  
II 1G Ex ia IIC T6
- Certified IMQ 08 ATEX 011 X
- Protected against any wrong connection
- Electromagnetic compatibility (EMC) according to EN60947-5-2
- According to: EN60947-5-6/EN60079-0/EN60079-11/EN60079-26
- Shock and vibration resistance according to EN60068-2-27/EN60068-2-6

### Safety parameters:

- $V_i$  max: 13,5 V
- $I_i$  max: 60 mA
- $C_i$  max: 100 nF
- $L_i$  max: 100 µH
- $P_i$  max: 200 mW

**These sensors must be used in conjunction with associated apparatus (See Sect. E)**

**Use in hazardous area according to instruction manuals**

Housing	Flush mounting Non flush mounting	L1	L2	L3	L4	L5	Cable diameter	Body diameter (d)	Max switching frequency (f)	Nominal sensing distance ( $S_n$ ) ± 10%	ORDERING REFERENCES	
		mm	mm	mm	mm	mm					mm	mm
B	•	-	30	-	-	30	4	M8 x 1	3	1,5	 <b>DC8/4600SA</b> <b>DC8/5600SA</b>	 <b>DC8/4610SA</b> <b>DC8/5610SA</b>
B	•	5	25	-	-	30	4	M8 x 1	2	2,5		



**NAMUR SERIES WITH LED diameters 12 - 18 - 30 mm •  
ATEX certified II 1GD for zone 0;20 •  
Cable output •**

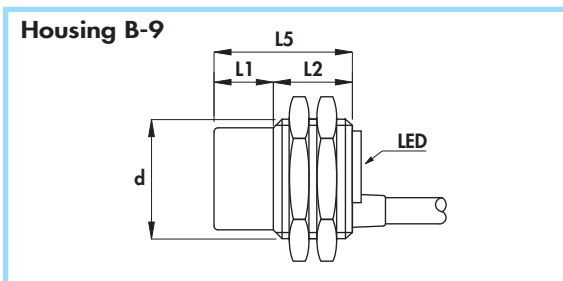
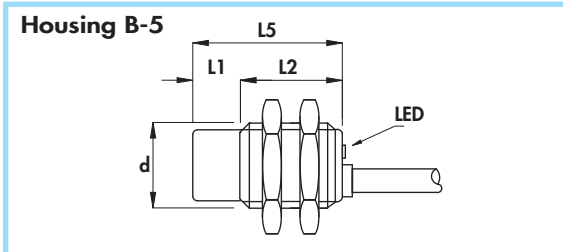
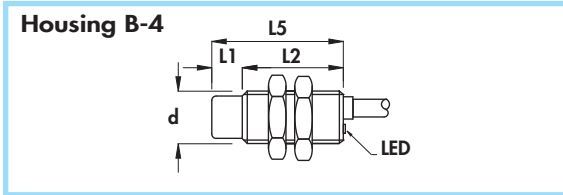

Diameter	M12 x 1	M18 x 1	M30 x 1,5
Nut	Size	SW17	SW24
	Thickness mm	4	4
Max tightening torque Nm	15	35	80

**Materials:**

- Cable: 2 m PVC CEI 20-22 II; 90°C; 300 V; O.R.
- Housing: nickel plated brass
- Sensing face: plastic

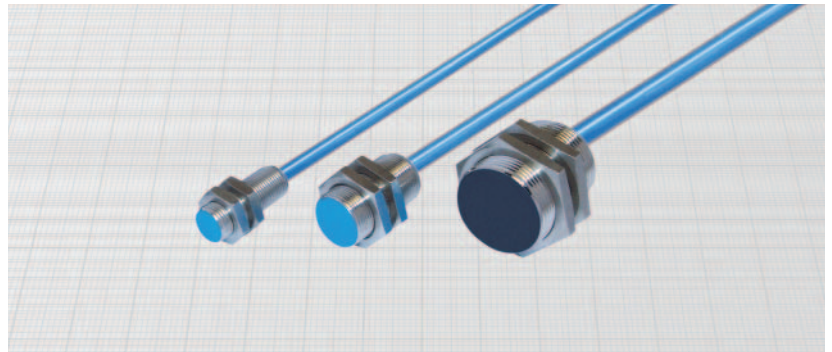

**General features:**

With this new series of sensors it's possible to drive specific inputs for NAMUR sensors or inputs for 2 wires amplified switches with low current (up to 10 mA). The load can be applied on both terminals (function PNP or NPN). The output is internally triggered and monitored by LED.

**Technical data:**

- Working voltage: 7,7 ÷ 9 Vdc
- Max ripple: 10%
- Off-state current (I<sub>o</sub>): ≤ 1 mA
- Minimum operational current (I<sub>m</sub>): 2 mA
- Rated operational current (I<sub>g</sub>): 10 mA
- Voltage drop (U<sub>d</sub>) with load 10 mA: < 6,5 V
- Voltage drop (U<sub>d</sub>) with load 8 mA: < 5 V
- Temperature range: - 20° ÷ +60°C
- Max thermal drift of sensing distance S<sub>p</sub>: ± 10%
- Repeat accuracy (R): 2%
- Switching hysteresis max (H): 10%
- Degree of protection: IP67
- Switch status indicator: yellow LED
- Cable conductor cross section: 0,35 mm<sup>2</sup> in diameter 12 mm  
0,75 mm<sup>2</sup> in diameters 18 and 30 mm

- Marking: II 1D Ex iaD 20 T80°C  
II 1G Ex ia IIC T6
- Certified IMQ 08 ATEX 010
- Protected against short-circuit and overload
- Protected against any wrong connection
- Electromagnetic compatibility (EMC) according to EN60947-5-2
- According to: EN60947-5-6/EN60079-0/EN60079-11/EN60079-26
- Shock and vibration resistance according to EN60068-2-27/EN60068-2-6

**Safety parameters:**

- Vi max: 13,5 V
- Ii max: 60 mA
- Ci max: 100 nF
- Li max: 100 µH
- Pi max: 200 mW

**These sensors must be used in conjunction with associated apparatus (See Sect. E)**

**Use in hazardous area according to instruction manuals**

Housing	Flush mounting Non flush mounting	L1	L2	L3	L4	L5	Cable diameter	Body diameter (d)	Max switching frequency (f)	Nominal sensing distance (S <sub>p</sub> ) ± 10%	ORDERING REFERENCES	
		mm	mm	mm	mm	mm						
B-4	•	-	30	-	-	30	4	M12 x 1	2	2	<b>DC12/4600KSA</b>	<b>DC12/4610KSA</b>
B-4	•	7	23	-	-	30	4	M12 x 1	1	4	<b>DC12/5600KSA</b>	<b>DC12/5610KSA</b>
B-5	•	-	30	-	-	30	5	M18 x 1	0,8	5	<b>DC18/4600KSA</b>	<b>DC18/4610KSA</b>
B-5	•	10	20	-	-	30	5	M18 x 1	0,6	8	<b>DC18/5600KSA</b>	<b>DC18/5610KSA</b>
B-9	•	-	35	-	-	35	5	M30 x 1,5	0,8	10	<b>DC30/4600KSA</b>	<b>DC30/4610KSA</b>
B-9	•	15	20	-	-	35	5	M30 x 1,5	0,4	15	<b>DC30/5600KSA</b>	<b>DC30/5610KSA</b>

# CYLINDRICAL INDUCTIVE ATEX SENSORS IN METAL HOUSING

- **NAMUR SERIES** diameter 8 mm
- **ATEX certified II 1GD for zone 0;20**
- Connector output M12x1

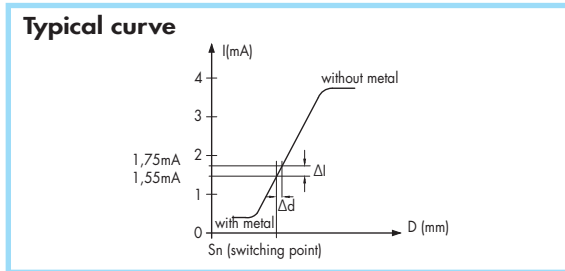
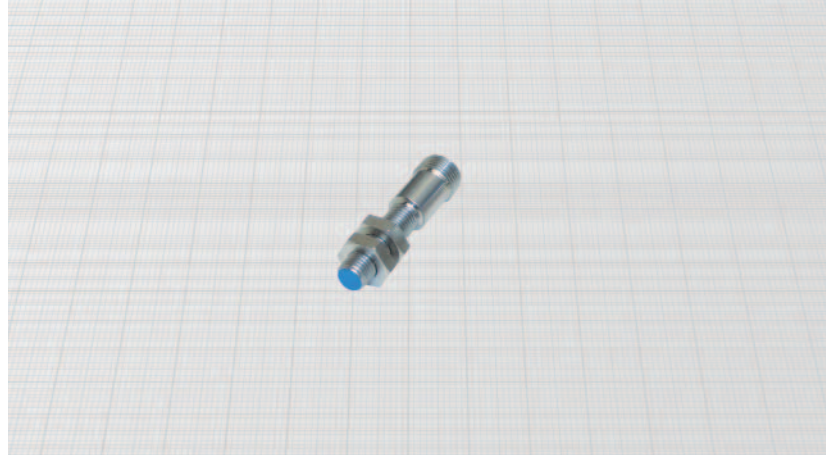
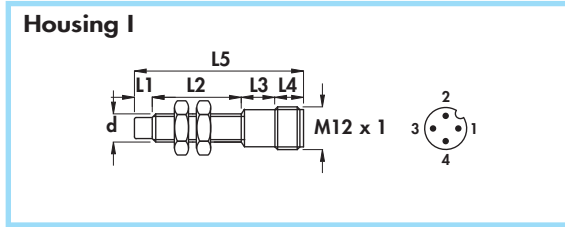

Diameter	M8 x 1	
Nut	Size	SW13
	Thickness mm	4
Max tightening torque Nm	10	

**Materials:**

- Housing: stainless steel
- Sensing face: plastic

**Technical data:**

- Supply voltage according NAMUR:  $7,7 \div 9$  Vdc
- Max ripple: 10%
- Consumption at 8,2 V with  $R_x = 1000 \Omega$ 
  - with metal:  $\leq 1$  mA
  - without metal:  $\geq 3$  mA
- Temperature range:  $-20^\circ \div +60^\circ\text{C}$
- Max thermal drift of sensing distance  $S_n$ :  $\pm 10\%$
- Repeat accuracy (R): 2%
- Degree of protection according EN60529: IP67
- Marking: II 1D Ex iaD 20 T80°C  
II 1G Ex ia IIC T6
- Certified IMQ 08 ATEX 011 X
- Electromagnetic compatibility (EMC) according to EN60947-5-2
- According to: EN60947-5-6/EN60079-0/EN60079-11/EN60079-26
- Shock and vibration resistance according to EN60068-2-27/EN60068-2-6

**Safety parameters:**

- $V_i$  max: 13,5 V
- $I_i$  max: 60 mA
- $C_i$  max: 100 nF
- $L_i$  max: 100  $\mu\text{H}$
- $P_i$  max: 200 mW

**These sensors must be used in conjunction with associated apparatus (See Sect. E)**

**Use in hazardous area according to instruction manuals**

Housing	Mounting Flush mounting Non flush mounting	L1	L2	L3	L4	L5	Female connector (see page G - 1)	Body diameter (d)	Max switching frequency (f)	Nominal sensing distance (S <sub>n</sub> ) $\pm 10\%$	ORDERING REFERENCES
		mm	mm	mm	mm	mm					
I	•	-	26	13	8	47	8B - 10	M8 x 1	4	1,5	DC8/4300A DC8/5300A
	•	5	21	13	8	47	8B - 10	M8 x 1	3	2,5	

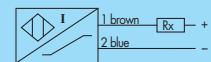



**NAMUR SERIES diameters 12 - 18 - 30 mm •  
ATEX certified II 1GD for zone 0;20 •  
Connector output M12x1 •**

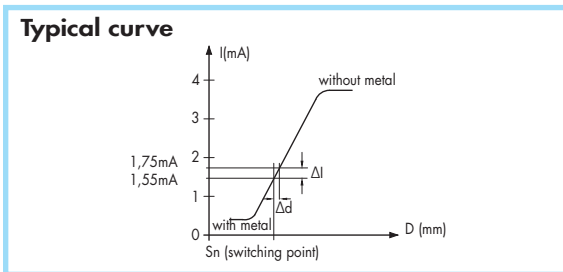
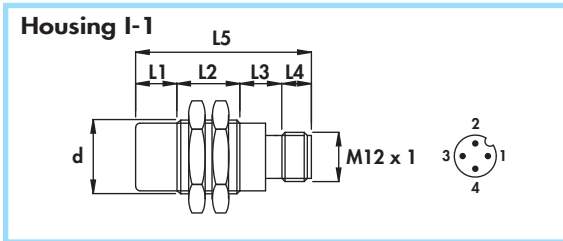
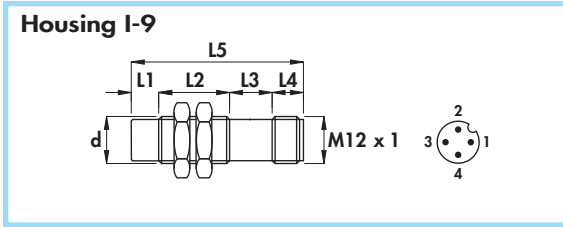

Diameter	M12 x 1	M18 x 1	M30 x 1,5
Nut	Size	SW17	SW24
	Thickness mm	4	4
Max tightening torque Nm	15	35	80

**Materials:**

- Housing: nickel plated brass
- Sensing face: plastic

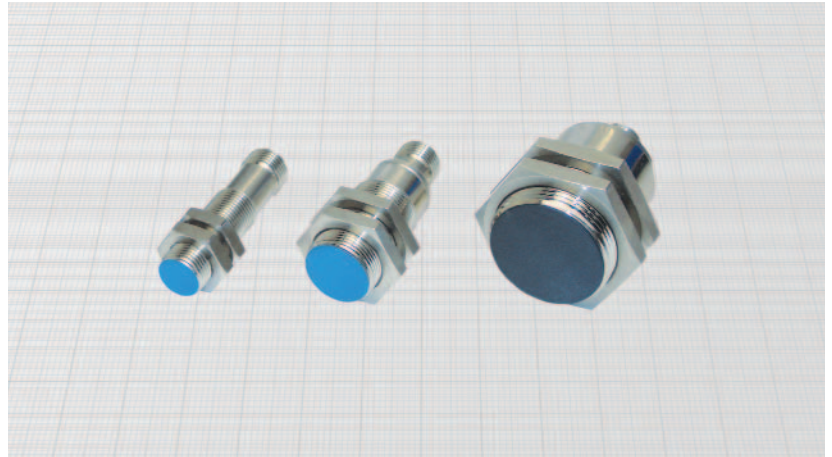

**Technical data:**

- Supply voltage according NAMUR: 7,7 ÷ 9 Vdc
- Max ripple: 10%
- Consumption at 8,2 V with Rx = 1000 Ω
  - without metal: ≤ 1 mA
  - with metal: ≥ 3 mA
- Temperature range: -20° ÷ +60°C
- Max thermal drift of sensing distance S<sub>r</sub>: ± 10%
- Repeat accuracy (R): 2%
- Degree of protection according EN60529: IP67
- Marking: II 1D Ex iaD 20 T80°C  
II 1G Ex ia IIC T6
- Certified IMQ 08 ATEX 010
- Electromagnetic compatibility (EMC) according to EN60947-5-2
- According to: EN60947-5-6/EN60079-0/EN60079-11/EN60079-26
- Shock and vibration resistance according to EN60068-2-27/EN60068-2-6

**Safety parameters:**

- V<sub>i</sub> max: 13,5 V
- I<sub>i</sub> max: 60 mA
- C<sub>i</sub> max: 100 nF
- L<sub>i</sub> max: 100 µH
- P<sub>i</sub> max: 200 mW

**These sensors must be used in conjunction with associated apparatus (See Sect. E)**

**Use in hazardous area according to instruction manuals**

Housing	Flush mounting Non flush mounting	L1	L2	L3	L4	L5	Female connector (see page G - 1)	Body diameter (d)	Max switching frequency (f)	Nominal sensing distance (S <sub>n</sub> ) ± 10%	ORDERING REFERENCES
		mm	mm	mm	mm	mm					
I-9	•	-	30	10	8	48	8B-10	M12 x 1	2	2	<b>DC12/4300A</b> <b>DC12/5300A</b>
I-9	•	7	23	10	8	48	8B-10	M12 x 1	1	4	
I-1	•	-	27	15	8	48	8B-10	M18 x 1	0,8	5	<b>DC18/4300A</b> <b>DC18/5300A</b>
I-1	•	10	17	15	8	48	8B-10	M18 x 1	0,6	8	
I-1	•	-	25	17	8	50	8B-10	M30 x 1,5	0,8	10	<b>DC30/4300A</b> <b>DC30/5300A</b>
I-1	•	15	25	17	8	65	8B-10	M30 x 1,5	0,4	15	

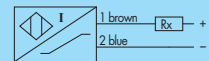



# CYLINDRICAL INDUCTIVE ATEX SENSORS IN METAL HOUSING

- NAMUR SERIES WITH LED diameter 8 mm
- ATEX certified II 1GD for zone 0;20
- Connector output M12 x 1

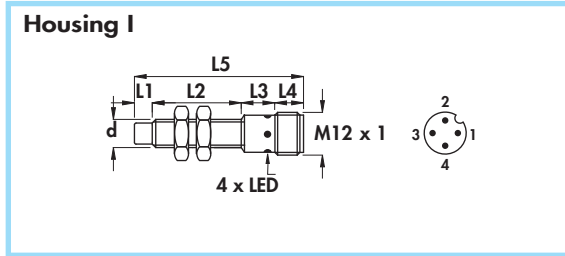

Diameter	M8 x 1	
Nut	Size	SW13
	Thickness mm	4
Max tightening torque Nm	10	

### Materials:

- Housing: stainless steel
- Sensing face: plastic

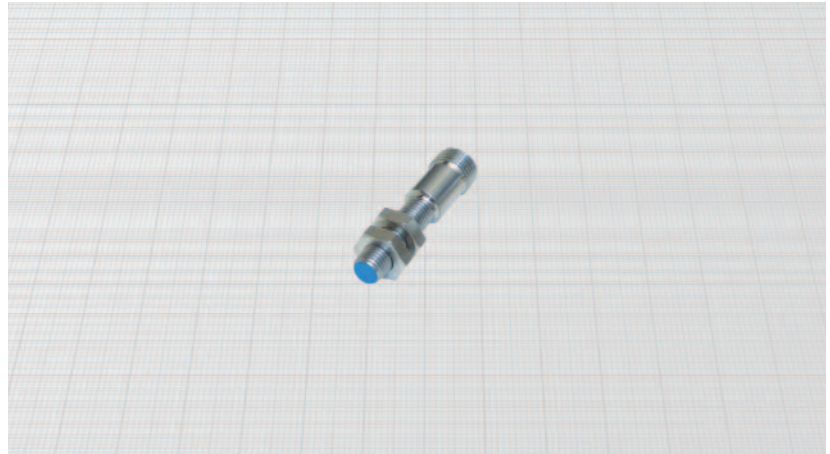

### General features:

With this new series of sensors it's possible to drive specific inputs for NAMUR sensors or inputs for 2 wires amplified switches with low current (up to 10 mA). The load can be applied on both terminals (function PNP or NPN). The output is internally triggered and monitored by LED.

### Technical data:

- Working voltage: 7,7 ÷ 9 Vdc
- Max ripple: 10%
- Off-state current ( $I_o$ ): ≤ 1 mA
- Minimum operational current ( $I_m$ ): 2 mA
- Rated operational current ( $I_a$ ): 10 mA
- Voltage drop ( $U_d$ ) with load 10 mA: < 6,5 V
- Voltage drop ( $U_d$ ) with load 8 mA: < 5 V
- Temperature range: - 20° ÷ +60°C
- Max thermal drift of sensing distance  $S_p$ : ± 10%
- Repeat accuracy (R): 2%
- Switching hysteresis max (H): 10%
- Degree of protection: IP67
- Switch status indicator: yellow LED
- Marking: II 1D Ex iaD 20 T80°C  
II 1G Ex ia IIC T6
- Certified IMQ 08 ATEX 011 X
- Protected against any wrong connection
- Electromagnetic compatibility (EMC) according to EN60947-5-2
- According to: EN60947-5-6/EN60079-0/EN60079-11/EN60079-26
- Shock and vibration resistance according to EN60068-2-27/EN60068-2-6

### Safety parameters:

- $V_i$  max: 13,5 V
- $I_i$  max: 60 mA
- $C_i$  max: 100 nF
- $L_i$  max: 100 µH
- $P_i$  max: 200 mW

**These sensors must be used in conjunction with associated apparatus (See Sect. E)**

**Use in hazardous area according to instruction manuals**

Housing	Flush mounting Non flush mounting	L1	L2	L3	L4	L5	Female connector (see page G-1)	Body diameter (d)	Max switching frequency (f)	Nominal sensing distance ( $S_n$ ) ± 10%	ORDERING REFERENCES	
											mm	mm
I	•	-	26	13	8	47	8B-10	M8 x 1	3	1,5		
	•	5	21	13	8	47	8B-10	M8 x 1	2	2,5		



**NAMUR SERIES WITH LED diameters 12 - 18 - 30 mm •  
ATEX certified II 1GD for zone 0;20 •  
Connector output M12 x 1 •**

**Housing I-9**

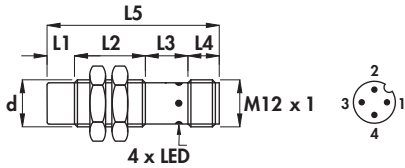

**Housing I-1**

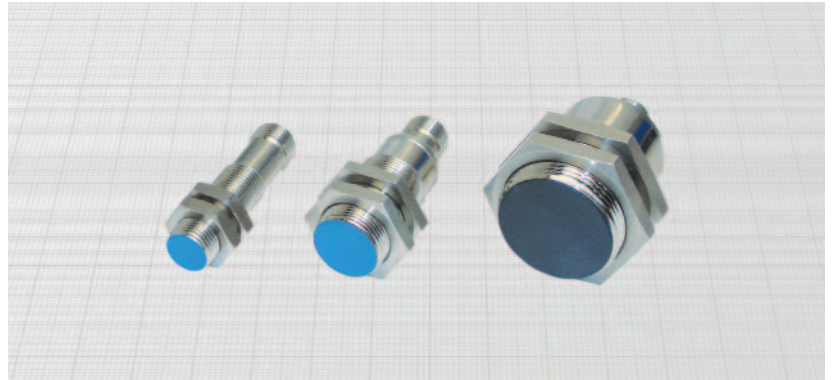
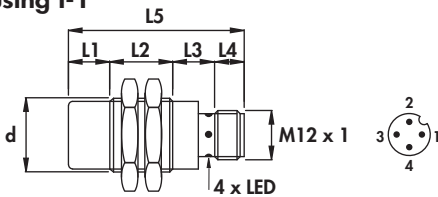

**General features:**

With this new series of sensors it's possible to drive specific inputs for NAMUR sensors or inputs for 2 wires amplified switches with low current (up to 10 mA). The load can be applied on both terminals (function PNP or NPN). The output is internally triggered and monitored by LED.

**Technical data:**

- Working voltage: 7,7 ÷ 9 Vdc
- Max ripple: 10%
- Off-state current (I<sub>o</sub>): ≤ 1 mA
- Minimum operational current (I<sub>m</sub>): 2 mA
- Rated operational current (I<sub>p</sub>): 10 mA
- Voltage drop (U<sub>d</sub>) with load 10 mA: < 6,5 V
- Voltage drop (U<sub>d</sub>) with load 8 mA: < 5 V
- Temperature range: -20° ÷ +60°C
- Max thermal drift of sensing distance S<sub>r</sub>: ± 10%
- Repeat accuracy (R): 2%
- Switching hysteresis max (H): 10%
- Degree of protection: IP67
- Switch status indicator: yellow LED
- Marking: II 1D Ex iaD 20 T80°C  
II 1G Ex ia IIC T6
- Certified IMQ 08 ATEX 010
- Protected against short-circuit and overload
- Protected against any wrong connection
- Electromagnetic compatibility (EMC) according to EN60947-5-2
- According to: EN60947-5-6/EN60079-0/EN60079-11/EN60079-26
- Shock and vibration resistance according to EN60068-2-27/EN60068-2-6

Diameter	M12 x 1	M18 x 1	M30 x 1,5
Nut	Size	SW17	SW24
	Thickness mm	4	4
Max tightening torque Nm	15	35	80

**Materials:**

- Housing: nickel plated brass
- Sensing face: plastic

**Safety parameters:**

- V<sub>i</sub> max: 13,5 V
- I<sub>i</sub> max: 60 mA
- C<sub>i</sub> max: 100 nF
- L<sub>i</sub> max: 100 µH
- P<sub>i</sub> max: 200 mW

**These sensors must be used in conjunction with associated apparatus (See Sect. E)**

**Use in hazardous area according to instruction manuals**

Housing	Flush mounting Non flush mounting	L1	L2	L3	L4	L5	Female connector (see page G - 1)	Body diameter (a)	Max switching frequency (f <sub>f</sub> )	Nominal sensing distance (S <sub>n</sub> ) ± 10%	ORDERING REFERENCES	
		mm	mm	mm	mm	mm						
I-9	•	-	30	10	8	48	8B - 10	M12 x 1	2	2	DC12/4300KSA	DC12/4310KSA
I-9	•	7	23	10	8	48	8B - 10	M12 x 1	1	4	DC12/5300KSA	DC12/5310KSA
I-1	•	-	27	15	8	49	8B - 10	M18 x 1	0,8	5	DC18/4300KSA	DC18/4310KSA
I-1	•	10	17	15	8	49	8B - 10	M18 x 1	0,6	8	DC18/5300KSA	DC18/5310KSA
I-1	•	-	25	17	8	50	8B - 10	M30 x 1,5	0,8	10	DC30/4300KSA	DC30/4310KSA
I-1	•	15	25	17	8	65	8B - 10	M30 x 1,5	0,4	15	DC30/5300KSA	DC30/5310KSA

# CYLINDRICAL INDUCTIVE ATEX SENSORS IN METAL HOUSING

- **NAMUR SERIES** For high temperatures  $\varnothing 6,5 - 8 \text{ mm}$  ( $-20^{\circ} \div + 110^{\circ} \text{ C}$ )
- **ATEX certified II 1GD** for zone 0;20
- Cable output



## Housing A

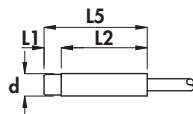

## Housing B

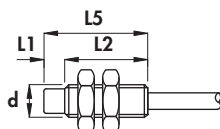

## Typical curve

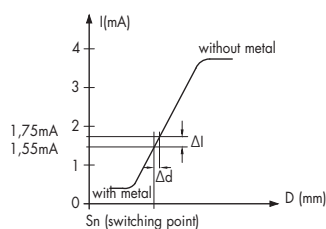

Diameter	M8 x 1	
Nut	Size	SW13
	Thickness mm	4
Max tightening torque Nm	10	

## Materials:

- Cable: 2 m thermoplastic 140°C; 300 V; O.R.
- Housing: stainless steel
- Sensing face: plastic

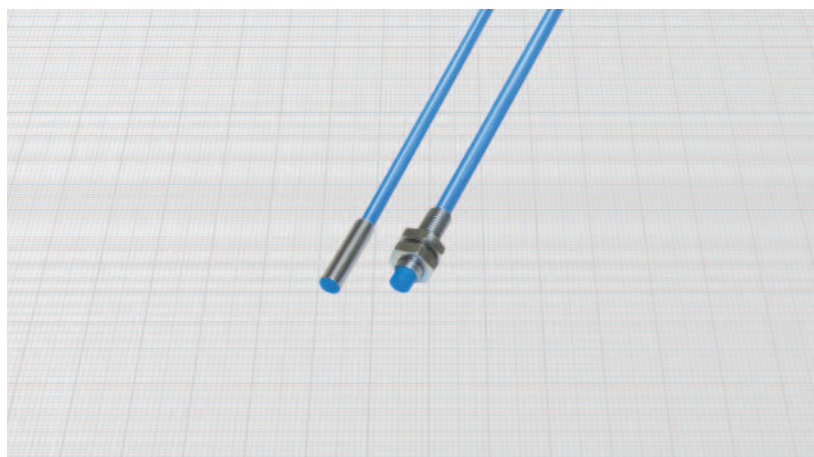

## Technical data:

- Supply voltage according NAMUR: 7,7 ÷ 9 Vdc
- Max ripple: 10%
- Consumption at 8,2 V with  $R_x = 1000 \Omega$ 
  - with metal:  $\leq 1 \text{ mA}$
  - without metal:  $\geq 3 \text{ mA}$
- Temperature range:  $-20^{\circ} \div + 110^{\circ} \text{ C}$
- Max thermal drift of sensing distance  $S_r$ :  $\pm 10\%$
- Repeat accuracy (R): 2%
- Degree of protection according EN60529: IP67
- Cable conductor cross section:
  - 0,35 mm<sup>2</sup> in diameters 6,5 ÷ 12 mm
  - 0,75 mm<sup>2</sup> in diameters 18 ÷ 45 mm
- Marking:
  - II 1D Ex iaD 20 T 130°C
  - II 1G Ex ia IIC T4
- Certified IMQ 08 ATEX 011 X
- Electromagnetic compatibility (EMC) according to EN60947-5-2
- According to: EN60947-5-6/EN60079-0/EN60079-11/EN60079-26
- Shock and vibration resistance according to EN60068-2-27/EN60068-2-6

## Safety parameters:

- $V_i$  max: 13,5 V
- $I_i$  max: 60 mA
- $C_i$  max: 100 nF
- $L_i$  max: 100  $\mu\text{H}$
- $P_i$  max: 200 mW

**These sensors must be used in conjunction with associated apparatus (See Sect. E)**

**Use in hazardous area according to instruction manuals**

Housing	Flush mounting Non flush mounting	L1	L2	L3	L4	L5	Cable diameter	Body diameter (d)	Max switching frequency (f)	Nominal sensing distance ( $S_n$ ) $\pm 10\%$	ORDERING REFERENCES 
		mm	mm	mm	mm	mm					
A	•	-	25	-	-	25	4	6,5	5	1,5	<b>DC6,5/4600LTA</b>
B	•	-	25	-	-	25	4	M8 x 1	5	1,5	<b>DC8/4600TA</b>



**NAMUR SERIES** For high temperatures Ø 12-18-30-45 mm (-20°÷+110°C) •  
ATEX certified II 1GD for zone 0;20 •  
Cable output •

**Housing B**

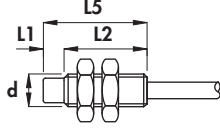

**Housing B-1**

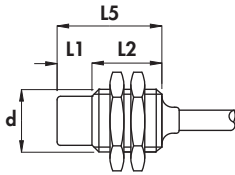

**Typical curve**

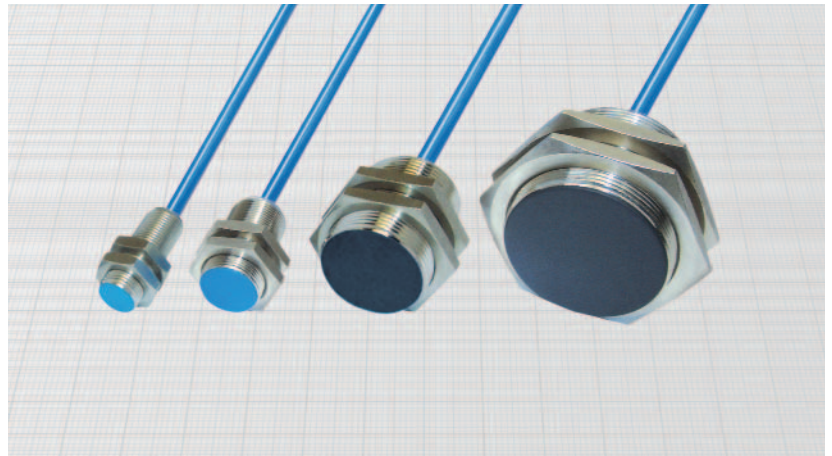
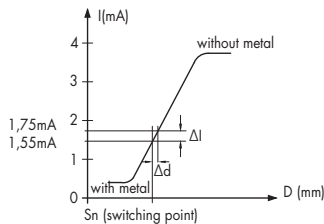

Diameter	M12 x 1	M18 x 1	M30 x 1,5	M45 x 1,5	
Nut	Size	SW17	SW24	SW36	SW55
	Thickness mm	4	4	5	5
Max tightening torque Nm	15	35	80	70	

**Materials:**

- Cable: 2 m thermoplastic 140°C; 300 V; O.R.
- Housing: nickel plated brass
- Sensing face: plastic

**Technical data:**

- Supply voltage according NAMUR: 7,7 ÷ 9 Vdc
- Max ripple: 10%
- Consumption at 8,2 V with Rx = 1000 Ω
  - with metal: ≤ 1 mA
  - without metal: ≥ 3 mA
- Temperature range: -20° ÷ +110°C
- Max thermal drift of sensing distance S<sub>r</sub>: ± 10%
- Repeat accuracy (R): 2%
- Degree of protection according EN60529: IP67
- Cable conductor cross section: 0,35 mm<sup>2</sup> in diameters 6,5 ÷ 12 mm  
0,75 mm<sup>2</sup> in diameters 18 ÷ 45 mm
- Marking: II 1D Ex iaD 20 T 130°C  
II 1G Ex ia IIC T4
- Certified IMQ 08 ATEX 010
- Electromagnetic compatibility (EMC) according to EN60947-5-2
- According to: EN60947-5-6/EN60079-0/EN60079-11/EN60079-26
- Shock and vibration resistance according to EN60068-2-27/EN60068-2-6

**Safety parameters:**

- V<sub>i</sub> max: 13,5 V
- I<sub>i</sub> max: 60 mA
- C<sub>i</sub> max: 100 nF
- L<sub>i</sub> max: 100 µH
- P<sub>i</sub> max: 200 mW

**These sensors must be used in conjunction with associated apparatus (See Sect. E)**

**Use in hazardous area according to instruction manuals**

Housing	Flush mounting Non flush mounting	L1	L2	L3	L4	L5	Cable diameter	Body diameter (d)	Max switching frequency (f)	Nominal sensing distance (S <sub>n</sub> ) ± 10%	ORDERING REFERENCES
		mm	mm	mm	mm	mm					
B	•	-	30	-	-	30	4	M12 x 1	5	2	<b>DC12/4600TA</b>
B-1	•	-	30	-	-	30	5	M18 x 1	1	5	<b>DC18/4600TA</b>
B-1	•	-	35	-	-	35	5	M30 x 1,5	0,3	10	<b>DC30/4600TA</b>
B-1	•	-	35	-	-	35	5	M45 x 1,5	0,3	20	<b>DC45/4600TA</b>

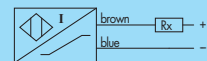

# CYLINDRICAL INDUCTIVE ATEX SENSORS IN METAL HOUSING

- **AMPLIFIED IN d.c. 3-wire**
- **ATEX certified II 1GD for zone 0;20**
- **Associated apparatus not required - Cable output**

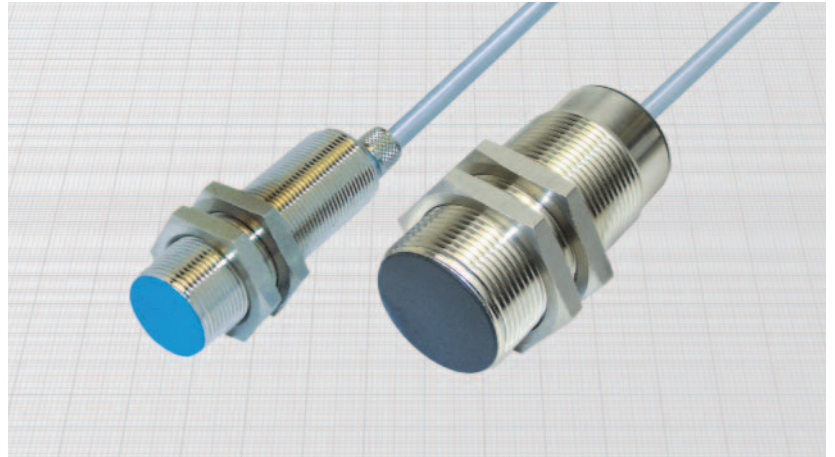
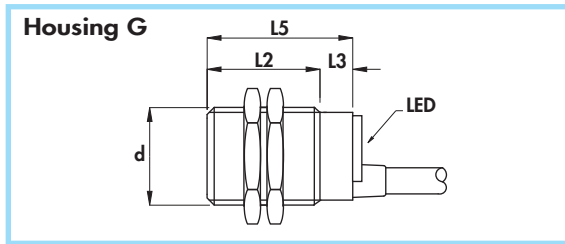
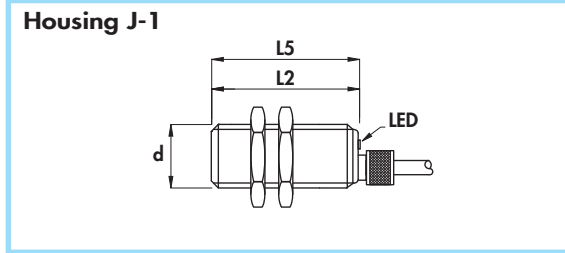

Diameter	M18 x 1	M30 x 1,5
Nut	Size	SW24
	Thickness mm	4
Max tightening torque Nm	35	80

### Materials:

- Cable: 2 m PVC; 90°C; 300 V; O.R.
- Housing: nickel plated brass
- Sensing face: plastic

### Technical data:

- Supply voltage ( $U_B$ ): 7 ÷ 30 Vdc
- Max ripple: 10%
- No-load supply current ( $I_0$ ): ≤ 10 mA
- Voltage drop ( $U_d$ ): < 1,5 V
- Temperature range: -20° ÷ +60°C
- Max storage temperature: +85°C
- Max thermal drift of sensing distance  $S_r$ : ± 10%
- Repeat accuracy (R): 4%
- Switching hysteresis max (H): 10%
- Degree of protection: IP67 for diameter 30 mm  
IP68 for diameter 18 mm

- Switch status indicator: yellow LED
- Cable conductor cross section: 0,50 mm<sup>2</sup>
- Marking: II 1D Ex maD 20 T80°C  
II 1G Ex ma II T6

- Certified IMQ 08 ATEX 002 X
- Protected against short-circuit and overload
- Protected against any wrong connection
- Suppression of initial false impulse
- Electromagnetic compatibility (EMC) according to EN60947-5-2
- According to: EN60079-0/EN60079-18/EN60079-26
- Shock and vibration resistance according to EN60068-2-27/EN60068-2-6

Use in hazardous area according to instruction manuals

Housing	Mounting	L2	L3	L4	L5	Cable diameter	Body diameter (d)	Max switching frequency (f)	Rated operational current (I <sub>e</sub> )	Nominal sensing distance (S <sub>n</sub> ) ± 10%	ORDERING REFERENCES	
											PNP (positive switching)	
J-1	Flush mounting	mm	mm	mm	mm	mm	mm	KHz	mA	mm		
	Non flush mounting										DCA18/4A09KSJMA	DCA18/4A19KSJMA
G		50	10	-	60	6	M30x1,5	0,1	400	10	DCA30/4609KSMA	DCA30/4619KSMA
<b>NPN (negative switching)</b>												
Use the above part number changing the last 9 with 8 (ie DCA18/4A08KSJMA)												



**AMPLIFIED IN d.c. 3-wire** •  
**ATEX certified II 2GD for zone 1;2I** •

Associated apparatus not required - Cable output •

### Housing B-3

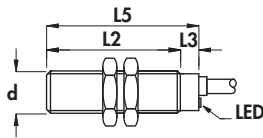

### Housing J-1

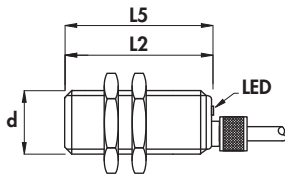

### Housing G

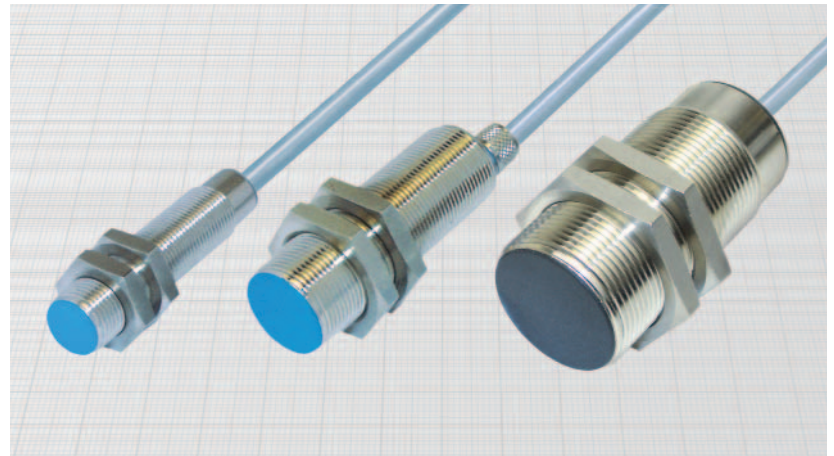
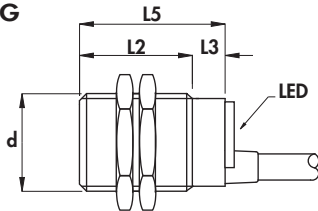

Diameter		M12 x 1	M18 x 1	M30 x 1,5
Nut	Size	SW17	SW24	SW36
	Thickness mm	4	4	5
Max tightening torque Nm		15	35	80

### Materials:

- Cable: 2 m PVC; 90°C; 300 V; O.R.
- Housing: nickel plated brass
- Sensing face: plastic

### Technical data:

- Supply voltage ( $U_B$ ):  $7 \div 30$  Vdc
- Max ripple: 10%
- No-load supply current ( $I_0$ ):  $\leq 10$  mA
- Voltage drop ( $U_d$ ):  $< 1,5$  V
- Temperature range:  $-20^\circ \div +60^\circ$  C
- Max storage temperature:  $+85^\circ$  C
- Max thermal drift of sensing distance  $S_T$ :  $\pm 10\%$
- Repeat accuracy (R): 2%
- Switching hysteresis max (H): 10%
- Degree of protection: IP67 for diameters 12 and 30 mm  
IP68 for diameter 18 mm

- Switch status indicator: yellow LED
- Cable conductor cross section:  $0,35$  mm<sup>2</sup> for diameter 12 mm  
 $0,50$  mm<sup>2</sup> for diameter 18 mm  
 $0,50$  mm<sup>2</sup> for diameter 30 mm

- Marking: II 2D Ex mbD 21 T80°C  
II 2G Ex mb II T6
- Certified IMQ 08 ATEX 002 X
- Protected against short-circuit and overload
- Protected against any wrong connection
- Suppression of initial false impulse
- Electromagnetic compatibility (EMC) according to EN60947-5-2
- According to: EN60079-0/EN60079-18/EN60079-26
- Shock and vibration resistance according to EN60068-2-27/EN60068-2-6

Use in hazardous area according to instruction manuals

Housing	Flush mounting Non flush mounting	L2	L3	L4	L5	Cable diameter	Body diameter (d)	Max switching frequency (f)	Rated operational current (I <sub>e</sub> )	Nominal sensing distance (S <sub>N</sub> ) ± 10%	ORDERING REFERENCES		
											PNP (positive switching)		
B - 3	•	43	7	-	50	4	M12 x 1	0,8	200	2	 <b>DCA12/4609KSMB</b> <b>DCA18/4A09KSJMB</b> <b>DCA30/4609KSMB</b>	 <b>DCA12/4619KSMB</b> <b>DCA18/4A19KSJMB</b> <b>DCA30/4619KSMB</b>	
J - 1	•	50	-	-	50	5	M18 x 1	0,3	400	5			
G	•	50	10	-	60	6	M30x1,5	0,1	400	10			
												NPN (negative switching)	
												Use the above part number changing the last 9 with 8 (ie DCA12/4608KSMB)	

# CYLINDRICAL INDUCTIVE ATEX SENSORS IN METAL HOUSING

- **AMPLIFIED IN d.c. 3 and 4-wire - diameters 6,5 - 8 mm**
- **ATEX certified II 3GD for zone 2;22**
- Cable output



## Housing A-3

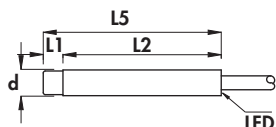

## Housing B-6

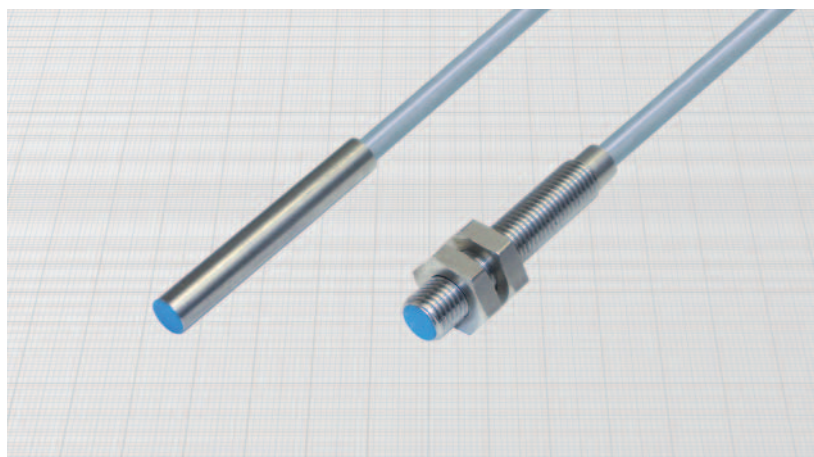
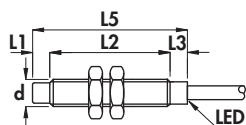

Diameter	M8 x 1	
Nut	Size	SW13
	Thickness mm	4
Max tightening torque Nm	10	

### Materials:

- Cable: 2 m PVC; 90°C; 300 V; O.R.
- Housing: stainless steel
- Sensing face: plastic

### Technical data:

- Supply voltage ( $U_b$ ): 7 ÷ 30 Vdc
- Max ripple: 10%
- No-load supply current ( $I_0$ ): ≤ 10 mA
- Voltage drop ( $U_d$ ): < 1,5 V
- Temperature range: -25° ÷ +60°C
- Max thermal drift of sensing distance  $S_r$ : ± 10%
- Repeat accuracy (R): 2%
- Switching hysteresis max (H): 10%
- Degree of protection: IP67
- Switch status indicator: yellow LED
- Cable conductor cross section: 0,15 mm<sup>2</sup> in 4-wire versions  
0,22 mm<sup>2</sup> in 3-wire versions

- Marking: II 3D Ex tc IIIC T80°C IP67 X  
II 3G Ex nAc IIC T6 X

- Protected against short-circuit and overload
- Protected against any wrong connection
- Suppression of initial false impulse
- Electromagnetic compatibility (EMC) according to EN60947-5-2
- According to: EN60079-0/EN60079-15/EN60079-31
- Shock and vibration resistance according to EN60068-2-27/EN60068-2-6



### Use in hazardous area according to instruction manuals

Housing	Flush mounting Non-flush mounting	L1	L2	L3	L5	Cable diameter	Body diameter (d)	Max switching frequency (F)	Rated operational current ( $I_e$ )	Nominal sensing distance ( $S_n$ ) ±10%	ORDERING REFERENCES		
											PNP (positive switching)		
											NO	NC	NO + NC
A-3	•	-	45	-	45	3,5	6,5	4	100	1,5	<b>DCA6,5/4609LKS3GD</b>	<b>DCA6,5/4619LKS3GD</b>	<b>DCA6,5/4629LKS3GD</b>
A-3	•	5	40	-	45	3,5	6,5	3	100	2,5	<b>DCA6,5/5609LKS3GD</b>	<b>DCA6,5/5619LKS3GD</b>	<b>DCA6,5/5629LKS3GD</b>
B-6	•	-	40	5	45	3,5	M8 x 1	4	100	1,5	<b>DCA8/4609KS3GD</b>	<b>DCA8/4619KS3GD</b>	<b>DCA8/4629KS3GD</b>
B-6	•	5	35	5	45	3,5	M8 x 1	3	100	2,5	<b>DCA8/5609KS3GD</b>	<b>DCA8/5619KS3GD</b>	<b>DCA8/5629KS3GD</b>
											NPN (negative switching)		
											Use the above part number changing the last 9 with 8 (ie DCA6,5/4608LKS3GD)		
											NO	NC	NO + NC



**AMPLIFIED IN d.c. 3-wire - diameter 12 mm •**  
**ATEX certified II 3GD for zone 2;22 •**  
**Cable output •**

**Housing B-3**

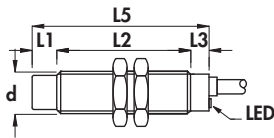

**Housing D**

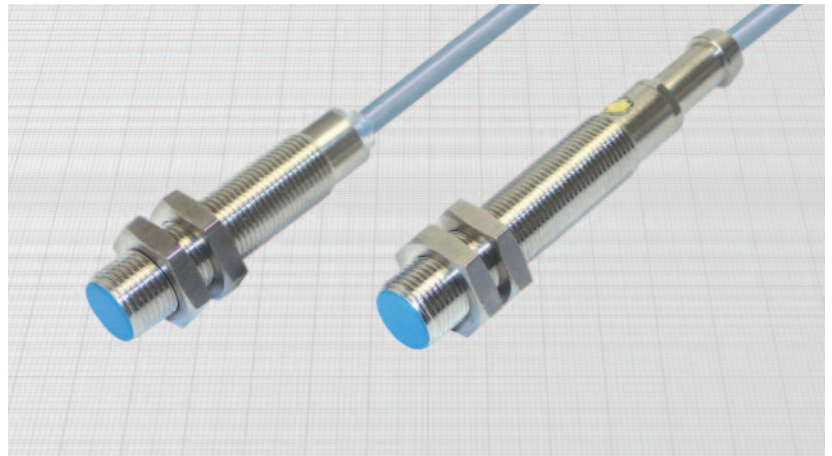
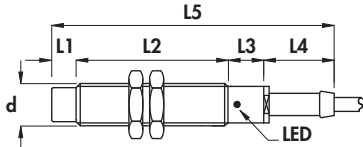

Diameter	M12 x 1	
Nut	Size	SW17
	Thickness mm	4
Max tightening torque Nm	15	

**Materials:**

- Cable: 2 m PVC; 90°C; 300 V; O.R.
- Housing: nickel plated brass
- Sensing face: plastic

**Technical data:**

- Supply voltage ( $U_B$ ): 5 ÷ 40 Vdc
- Max ripple: 10%
- No-load supply current ( $I_0$ ): ≤ 10 mA
- Voltage drop ( $U_d$ ): < 1,5 V
- Temperature range: -25° ÷ +60°C
- Max thermal drift of sensing distance  $S_r$ : ± 10%
- Repeat accuracy (R): 2%
- Switching hysteresis max (H): 10%
- Degree of protection: IP67
- Switch status indicator: yellow LED
- Cable conductor cross section: 0,35 mm<sup>2</sup> in 3-wire versions  
0,25 mm<sup>2</sup> in 4-wire versions

- Marking: II 3D Ex tc IIIC T80°C IP67 X  
II 3G Ex nAc IIC T6 X
- Protected against short-circuit and overload
- Protected against any wrong connection
- Suppression of initial false impulse
- Electromagnetic compatibility (EMC) according to EN60947-5-2
- According to: EN60079-0/EN60079-15/EN60079-31
- Shock and vibration resistance according to EN60068-2-27/EN60068-2-6

**Use in hazardous area according to instruction manuals**

Housing	Flush mounting Non flush mounting	L1	L2	L3	L4	L5	Cable diameter	Body diameter (d)	Max switching frequency (f)	Rated operational current (I <sub>e</sub> )	Nominal sensing distance (S <sub>N</sub> ) ±10%	ORDERING REFERENCES		
												mm	mm	mm
B-3	•	-	43	7	-	50	4	M12 x 1	2	100	2	<b>PNP (positive switching)</b> NO brown, black, blue NC brown, black, blue NO+NC brown, black, white, blue		
D	•	-	50	10	20	80	4	M12 x 1	2	100	2	DCA12/4609KS3GD	DCA12/4619KS3GD	DCA12/4629KS3GD
B-3	•	7	36	7	-	50	4	M12 x 1	1,5	100	4	DCA12/4709KS3GD	DCA12/4719KS3GD	DCA12/4729KS3GD
D	•	7	43	10	20	80	4	M12 x 1	1,5	100	4	DCA12/5609KS3GD	DCA12/5619KS3GD	DCA12/5629KS3GD
												<b>NPN (negative switching)</b> Use the above part number changing the last 9 with 8 (ie DCA12/4608KS3GD)		
												NO brown, black, blue NC brown, black, blue NO+NC brown, black, white, blue		



# CYLINDRICAL INDUCTIVE ATEX SENSORS IN METAL HOUSING

- **AMPLIFIED IN d.c. 3-wire** - diameters 18 - 30 - 45 mm
- **ATEX certified II 3GD for zone 2;22**
- Cable output

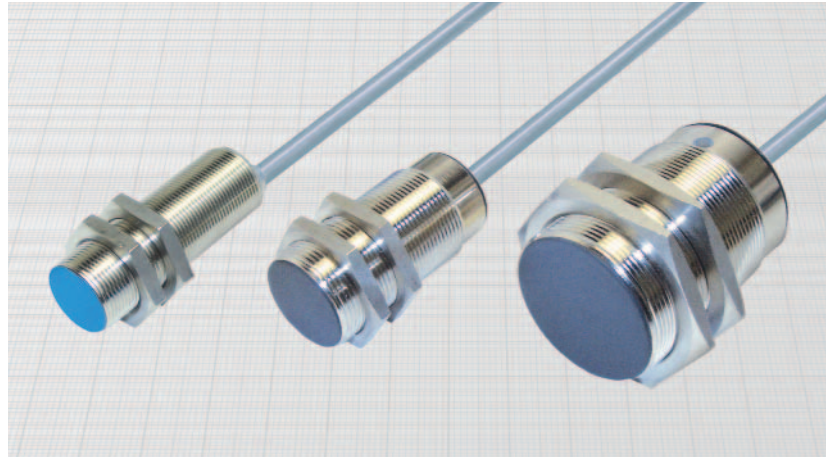
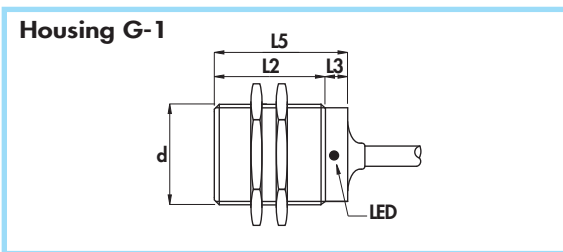
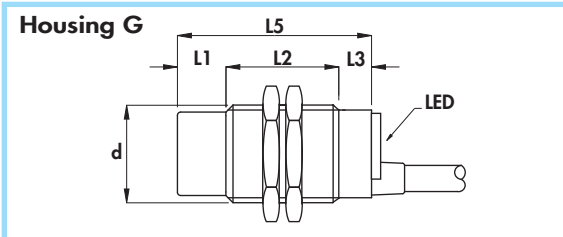
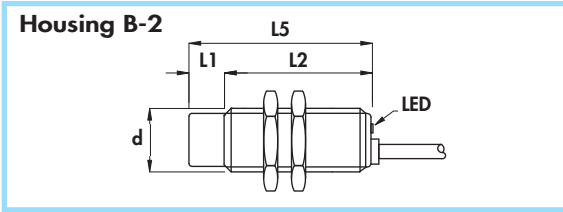

Diameter	M18 x 1	M30 x 1,5	M45 x 1,5
Nut	Size	SW24	SW36
	Thickness mm	4	5
Max tightening torque Nm	35	80	70

### Materials:

- Cable: 2 m PVC; 90°C; 300 V; O.R.
- Housing: nickel plated brass
- Sensing face: plastic

### Technical data:

- Supply voltage ( $U_B$ ): diameter 18 mm: 5 ÷ 60 Vdc  
diameters 30 - 45 mm: 7 ÷ 60 Vdc
- Max ripple: 10%
- No-load supply current ( $I_0$ ): ≤ 10 mA
- Voltage drop ( $U_d$ ): < 2,2 V
- Temperature range: - 25° ÷ + 60°C
- Max thermal drift of sensing distance  $S_T$ : ± 10%
- Repeat accuracy (R): 2%
- Switching hysteresis max (H): 10%
- Degree of protection: IP67
- Switch status indicator: yellow LED
- Cable conductor cross section: 0,50 mm<sup>2</sup> in 3-wire version diameter 18 mm  
0,35 mm<sup>2</sup> in 4-wire version diameter 18 mm  
0,50 mm<sup>2</sup> for diameters 30 and 45 mm
- Marking: II 3D Ex tc IIIC T80°C IP67 X  
II 3G Ex nAc IIC T6 X
- Protected against short-circuit and overload
- Protected against any wrong connection
- Suppression of initial false impulse
- Electromagnetic compatibility (EMC) according to EN60947-5-2
- According to: EN60079-0/EN60079-15/EN60079-31
- Shock and vibration resistance according to EN60068-2-27/EN60068-2-6

Use in hazardous area according to instruction manuals

Housing	Flush mounting Non flush mounting	L1	L2	L3	L4	L5	Cable diameter	Body diameter (d)	Max switching frequency (f)	Rated operational current (I <sub>e</sub> )	Nominal sensing distance (S <sub>n</sub> ) ±10%	ORDERING REFERENCES		
												PNP (positive switching)		
												NO	NC	NO + NC
B-2	•	-	50	-	-	50	5	M18 x 1	1	200	5	DCA18/4A09KS3GD	DCA18/4A19KS3GD	DCA18/4A29KS3GD
B-2	•	10	40	-	-	50	5	M18 x 1	1	200	8	DCA18/5A09KS3GD	DCA18/5A19KS3GD	DCA18/5A29KS3GD
G	•	-	50	10	-	60	6	M30 x 1,5	0,8	200	10	DCA30/4609KS3GD	DCA30/4619KS3GD	DCA30/4629KS3GD
G	•	15	35	10	-	90	6	M30 x 1,5	0,4	200	15	DCA30/5609KS3GD	DCA30/5619KS3GD	DCA30/5629KS3GD
G-1	•	10	50	10	-	60	6	M45 x 1,5	0,15	200	20	DCA45/4609KS3GD	DCA45/4619KS3GD	DCA45/4629KS3GD
												NPN (negative switching)		
												Use the above part number changing the last 9 with 8 (ie DCA18/4A08KS3GD)		
												NO	NC	NO + NC



**AMPLIFIED IN d.c.** •  
**ATEX certified II 3GD for zone 2;22** •  
**Connector output M12x1** •

**Housing I-11**

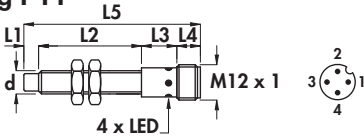

**Housing I-7**

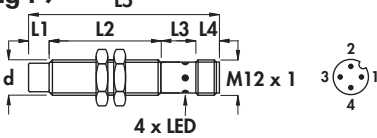

**Housing I-12**

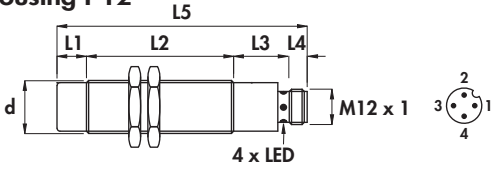

**Housing I-2**

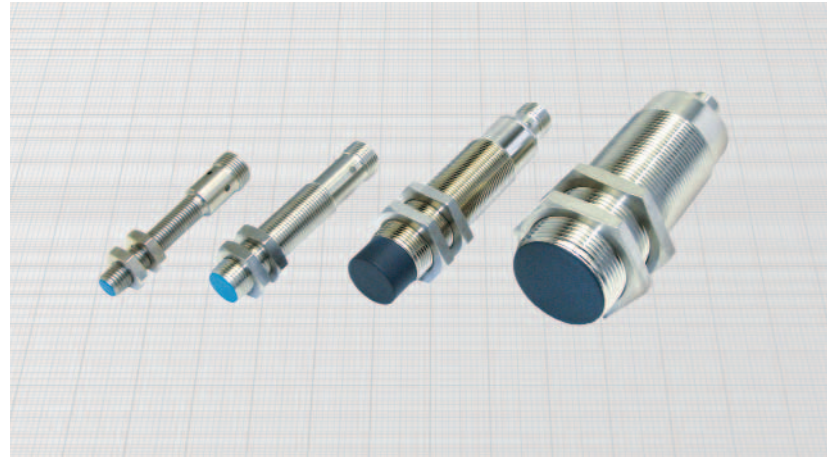
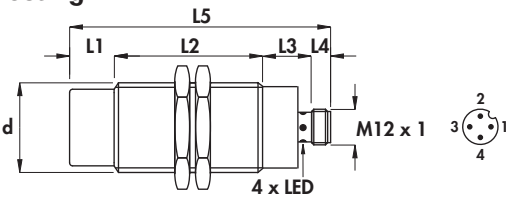

Diameter		M8 x 1	M12 x 1	M18 x 1	M30 x 1,5
Nut	Size	SW13	SW17	SW24	SW36
	Thickness mm	4	4	4	5
Max tightening torque Nm		10	15	35	80

**Materials:**

- Housing diameter 8 mm: stainless steel
- Housing diameters 12 ÷ 30 mm: nickel plated brass
- Sensing face: plastic

**Technical data:**

- Supply voltage ( $U_B$ ): see ordering references
- Max ripple: 10%
- Rated operational current ( $I_B$ ): 100 mA
- No-load supply current ( $I_0$ ): ≤ 10 mA
- Voltage drop ( $U_d$ ): < 1,5 V
- Temperature range: -25° ÷ +60°C
- Max thermal drift of sensing distance  $S_r$ : ± 10%
- Repeat accuracy (R): 2%
- Switching hysteresis max (H): 10%
- Degree of protection: IP67
- Switch status indicator: yellow LED
- Marking: II 3D Ex tc IIIC T80°C IP67 X  
II 3G Ex nAc IIC T6 X
- Protected against short-circuit and overload
- Protected against any wrong connection
- Suppression of initial false impulse
- Electromagnetic compatibility (EMC) according to EN60947-5-2
- According to: EN60079-0/EN60079-15/EN60079-31
- Shock and vibration resistance according to EN60068-2-27/EN60068-2-6

**Use in hazardous area according to instruction manuals**

Housing	Flush mounting Non flush mounting	L1	L2	L3	L4	L5	Female connector (see page G - 1)	Body diameter (d)	Supply voltage ( $U_B$ )	Max switching frequency (f)	Nominal sensing distance ( $S_r$ ) ± 10%	ORDERING REFERENCES		
												PNP (positive switching)		
		mm	mm	mm	mm	mm	n°	mm	(min - V - max)	KHz	mm	NO	NC	NO + NC
I-11	•	-	40	12	8	60	8B-10	M8 x 1	7 ÷ 30	4	1,5			
I-11	•	5	35	12	8	60	8B-10	M8 x 1	7 ÷ 30	3	2,5	DCA8/4309KS3GD	DCA8/43C9KS3GD	DCA8/4329KS3GD
												DCA8/5309KS3GD	DCA8/53C9KS3GD	DCA8/5329KS3GD
I-7	•	-	43	15	8	66	8B-10	M12 x 1	5 ÷ 40	2	2			
I-7	•	7	36	15	8	66	8B-10	M12 x 1	5 ÷ 40	1,5	4	DCA12/4309KS3GD	DCA12/43C9KS3GD	DCA12/4329KS3GD
												DCA12/5309KS3GD	DCA12/53C9KS3GD	DCA12/5329KS3GD
I-12	•	-	50	19	8	77	8B-10	M18 x 1	5 ÷ 60	1	5			
I-12	•	10	50	19	8	87	8B-10	M18 x 1	5 ÷ 60	1	8	DCA18/4309KS3GD	DCA18/43C9KS3GD	DCA18/4329KS3GD
												DCA18/5309KS3GD	DCA18/53C9KS3GD	DCA18/5329KS3GD
I-2	•	-	65	17	8	90	8B-10	M30x1,5	7 ÷ 60	0,8	10			
I-2	•	15	50	17	8	90	8B-10	M30x1,5	7 ÷ 60	0,4	15	DCA30/4309KS3GD	DCA30/43C9KS3GD	DCA30/4329KS3GD
												DCA30/5309KS3GD	DCA30/53C9KS3GD	DCA30/5329KS3GD
												NPN (negative switching)		
												Use the above part number changing the last 9 with 8 (ie DCA8/4308KS3GD)		
		mm	mm	mm	mm	mm	n°	mm	(min - V - max)	KHz	mm	NO	NC	NO + NC

# CYLINDRICAL INDUCTIVE ATEX SENSORS IN METAL HOUSING

- **AMPLIFIED IN d.c. 3-wire - SHORT SERIES**
- **ATEX certified II 3GD for zone 2;22**
- Cable output

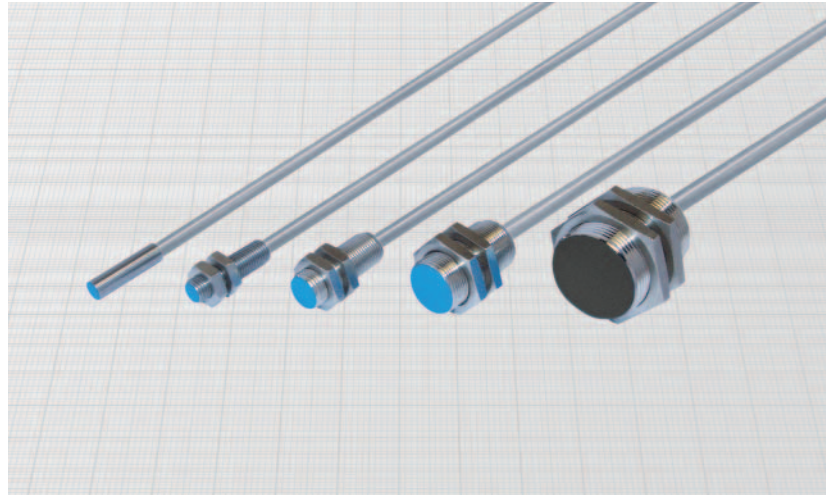
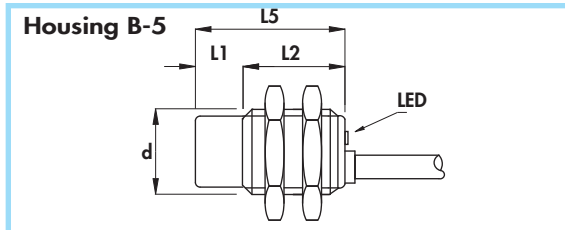
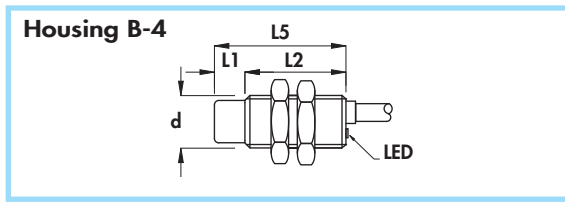
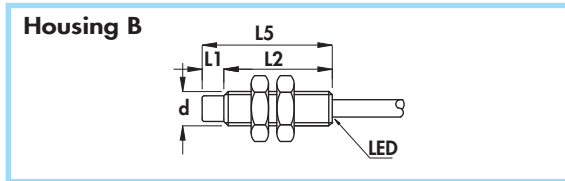
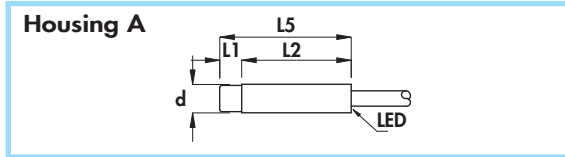

Diameter	M8 x 1	M12 x 1	M18 x 1	M30 x 1,5
Nut	Size	SW13	SW17	SW24
	Thickness mm	4	4	5
Max tightening torque Nm	10	15	35	80

## Materials:

- Cable: 2 m PVC CEI 20 - 22 II; 90°C; 300 V; O.R.
- Housing diameters 6,5 and 8 mm: stainless steel
- Housing diameters 12 ÷ 30 mm: nickel plated brass
- Sensing face: plastic

## Technical data:

- Supply voltage ( $U_b$ ): see ordering references
- Max ripple: 10%
- No-load supply current ( $I_o$ ):  $\leq 10$  mA
- Voltage drop ( $U_d$ ):  $\leq 1,5$  V
- Temperature range:  $-25^\circ \div +60^\circ$  C
- Max thermal drift of sensing distance  $S_T$ :  $\pm 10\%$
- Repeat accuracy (R): 2%
- Switching hysteresis max (H): 10%
- Degree of protection: IP67
- Switch status indicator: yellow LED
- Cable conductor cross section: 0,22 mm<sup>2</sup> in diameters 6,5 and 8 mm  
0,35 mm<sup>2</sup> in diameter 12 mm  
0,50 mm<sup>2</sup> in diameters 18 and 30 mm

- Marking: II 3D Ex tc IIIC T80°C IP67 X  
II 3G Ex nAc IIC T6 X

- Protected against short-circuit and overload
- Protected against any wrong connection
- Suppression of initial false impulse
- Electromagnetic compatibility (EMC) according to EN60947-5-2
- According to: EN60079-0/EN60079-15/EN60079-31
- Shock and vibration resistance according to EN60068-2-27/EN60068-2-6



## Use in hazardous area according to instruction manuals

Housing	Flush mounting Non flush mounting	L1	L2	L3	L4	L5	Cable diameter	Body diameter (d)	Supply voltage ( $U_b$ )	Max switching frequency (f)	Rated operational current ( $I_o$ )	Nominal sensing distance ( $S_n$ ) $\pm 10\%$	ORDERING REFERENCES		
													PNP (positive switching)		
A	•	-	30	-	-	30	3,5	6,5	7 ÷ 30	4	200	1,5		<b>DSA6,5/4609LKS3GD</b>	<b>DSA6,5/4619LKS3GD</b>
A	•	5	25	-	-	30	3,5	6,5	7 ÷ 30	3	200	2,5		<b>DSA6,5/5609LKS3GD</b>	<b>DSA6,5/5619LKS3GD</b>
B	•	-	30	-	-	30	3,5	M8 x 1	7 ÷ 30	4	200	1,5		<b>DSA8/4609KS3GD</b>	<b>DSA8/4619KS3GD</b>
B	•	5	25	-	-	30	3,5	M8 x 1	7 ÷ 30	3	200	2,5		<b>DSA8/5609KS3GD</b>	<b>DSA8/5619KS3GD</b>
B-4	•	-	30	-	-	30	4	M12 x 1	7 ÷ 30	2	200	2		<b>DSA12/4609KS3GD</b>	<b>DSA12/4619KS3GD</b>
B-4	•	7	23	-	-	30	4	M12 x 1	7 ÷ 30	1,5	200	4		<b>DSA12/5609KS3GD</b>	<b>DSA12/5619KS3GD</b>
B-5	•	-	30	-	-	30	5	M18 x 1	5 ÷ 40	0,8	200	5		<b>DSA18/4609KS3GD</b>	<b>DSA18/4619KS3GD</b>
B-5	•	10	20	-	-	30	5	M18 x 1	5 ÷ 40	0,6	200	8		<b>DSA18/5609KS3GD</b>	<b>DSA18/5619KS3GD</b>
B-5	•	-	35	-	-	35	6	M30 x 1,5	7 ÷ 40	0,8	200	10		<b>DSA30/4609KS3GD</b>	<b>DSA30/4619KS3GD</b>
B-5	•	15	20	-	-	35	6	M30 x 1,5	7 ÷ 40	0,4	200	15		<b>DSA30/5609KS3GD</b>	<b>DSA30/5619KS3GD</b>

## NPN (negative switching)

Use the above part number changing the last 9 with 8 (ie DSA6,5/4608LKS3GD)

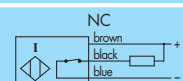
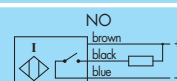



**AMPLIFIED IN d.c. - SHORT SERIES •**  
**ATEX certified II 3GD for zone 2;22 •**  
 Connector output M12 x 1 •

**Housing I**

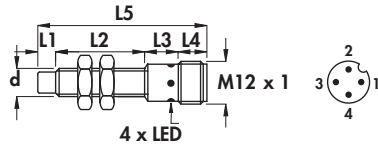

**Housing I-9**

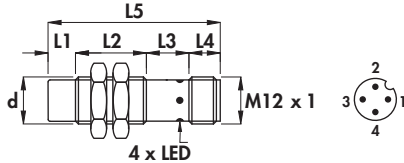

**Housing I-1**

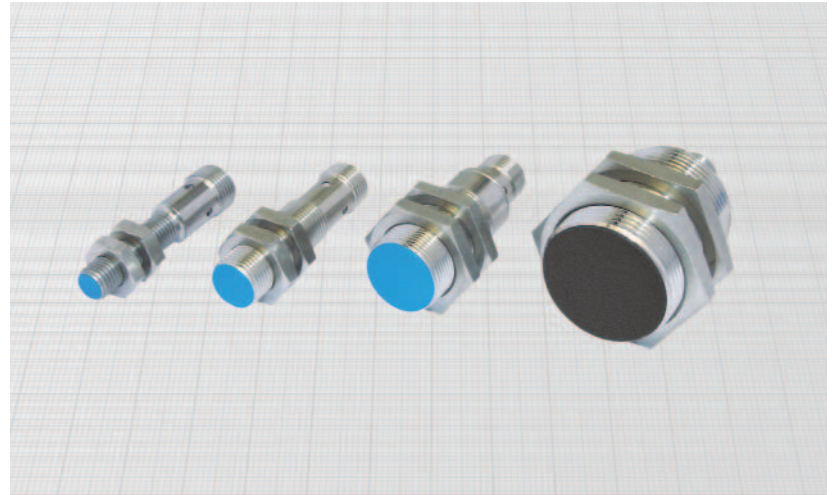
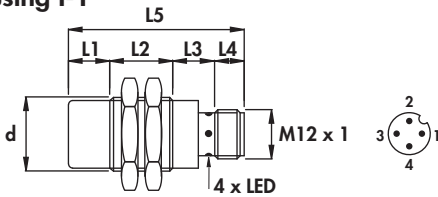

Diameter	M8 x 1	M12 x 1	M18 x 1	M30 x 1,5	
Nut	Size	SW13	SW17	SW24	SW36
	Thickness mm	4	4	4	5
Max tightening torque Nm	10	15	35	80	

**Materials:**

- Housing diameter 8 mm: stainless steel
- Housing diameters 12 ÷ 30 mm: nickel plated brass
- Sensing face: plastic

**Technical data:**

- Supply voltage ( $U_B$ ): see ordering references
- Max ripple: 10%
- No-load supply current ( $I_0$ ): ≤ 10 mA
- Voltage drop ( $U_d$ ): ≤ 1,5 V
- Temperature range: -25° ÷ +60°C
- Max thermal drift of sensing distance  $S_r$ : ± 10%
- Repeat accuracy (R): 2%
- Switching hysteresis max (H): 10%
- Degree of protection: IP67
- Switch status indicator: yellow LED
- Marking: II 3D Ex tc IIIC T80°C IP67 X  
II 3G Ex nAc IIC T6 X
- Protected against short-circuit and overload
- Protected against any wrong connection
- Suppression of initial false impulse
- Electromagnetic compatibility (EMC) according to EN60947-5-2
- According to: EN60079-0/EN60079-15/EN60079-31
- Shock and vibration resistance according to EN60068-2-27/EN60068-2-6

**Use in hazardous area according to instruction manuals**

Housing	Flush mounting Non flush mounting	L1	L2	L3	L4	L5	Female connector (see page G-1)	Body diameter (d)	Supply voltage ( $U_B$ )	Max switching frequency (f)	Rated operational current ( $I_0$ )	Nominal sensing distance ( $S_n$ ) ± 10%	ORDERING REFERENCES	
													PNP (positive switching)	
													NO	NC
I	•	-	26	13	8	47	6-8B-10	M8 x 1	7 ÷ 30	4	200	1,5		
	•	5	21	13	8	47	6-8B-10	M8 x 1	7 ÷ 30	3	200	2,5	<b>DSA8/4309KS3GD</b>	<b>DSA8/43C9KS3GD</b>
													<b>DSA8/5309KS3GD</b>	<b>DSA8/53C9KS3GD</b>
I-9	•	-	30	10	8	48	6-8B-10	M12 x 1	7 ÷ 30	2	200	2		
	•	7	23	10	8	48	6-8B-10	M12 x 1	7 ÷ 30	1	200	4	<b>DSA12/4309KS3GD</b>	<b>DSA12/43C9KS3GD</b>
													<b>DSA12/5309KS3GD</b>	<b>DSA12/53C9KS3GD</b>
I-1	•	-	25	16	8	49	6-8B-10	M18 x 1	5 ÷ 40	0,8	200	5		
	•	10	15	16	8	49	6-8B-10	M18 x 1	5 ÷ 40	0,6	200	8	<b>DSA18/4309KS3GD</b>	<b>DSA18/43C9KS3GD</b>
													<b>DSA18/5309KS3GD</b>	<b>DSA18/53C9KS3GD</b>
I-1	•	-	25	17	8	50	6-8B-10	M30 x 1,5	7 ÷ 40	0,8	200	10		
	•	15	25	17	8	65	6-8B-10	M30 x 1,5	7 ÷ 40	0,4	200	15	<b>DSA30/4309KS3GD</b>	<b>DSA30/43C9KS3GD</b>
													<b>DSA30/5309KS3GD</b>	<b>DSA30/53C9KS3GD</b>

**NPN (negative switching)**

Use the above part number changing the last 9 with 8 (ie DSA8/4308KS3GD)

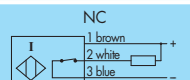
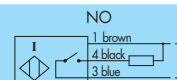

# CYLINDRICAL INDUCTIVE ATEX SENSORS IN METAL HOUSING

- **AMPLIFIED IN d.c. 3-wire** - Extended sensing distance
- **ATEX certified II 3GD for zone 2;22**
- Cable output

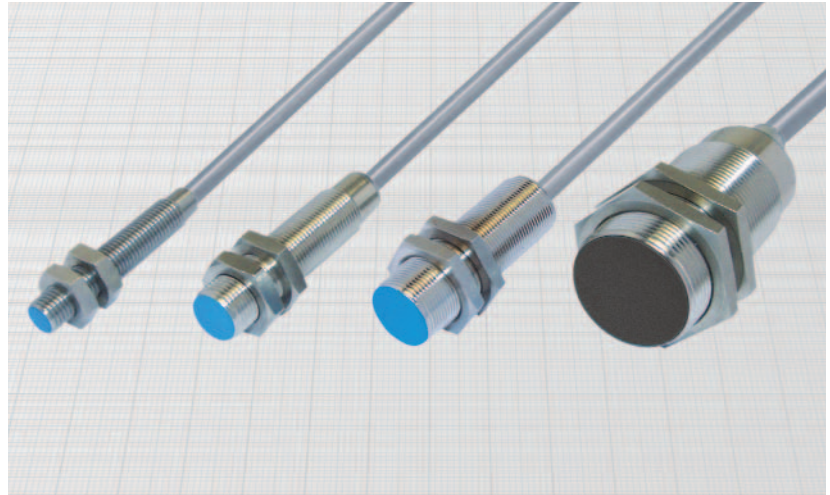
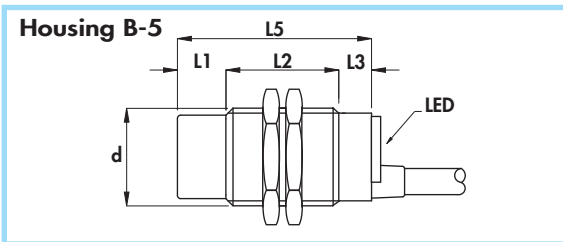
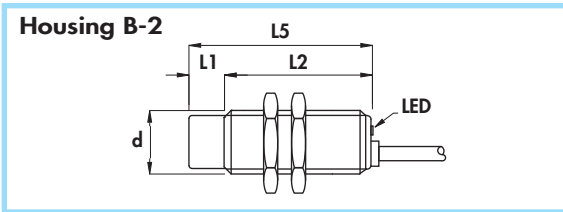
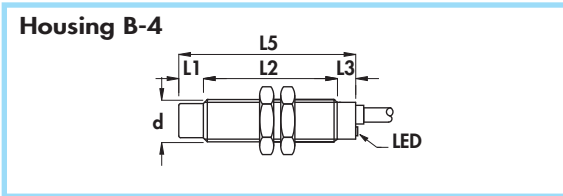
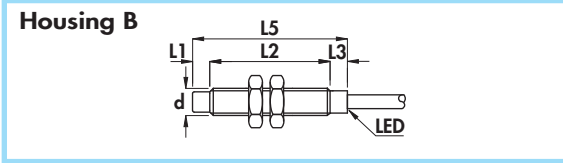

Diameter	M8 x 1	M12 x 1	M18 x 1	M30 x 1,5
Nut	Size SW13	SW17	SW24	SW36
	Thickness mm 4	4	4	5
Max tightening torque Nm	10	15	35	80

## Materials:

- Cable: 2 m PVC CEI 20 - 22 II; 90°C; 300 V; O.R.
- Housing diameters 6,5 and 8 mm: stainless steel
- Housing diameters 12 ÷ 30 mm: nickel plated brass
- Sensing face: plastic

## Technical data:

- Supply voltage ( $U_B$ ): see ordering references
- Max ripple: 10%
- No-load supply current ( $I_0$ ):  $\leq 10$  mA
- Voltage drop ( $U_d$ ):  $\leq 1,5$  V
- Temperature range:  $-25^\circ \div +60^\circ\text{C}$
- Max thermal drift of sensing distance  $S_s$ :  $\pm 10\%$
- Repeat accuracy (R): 4%
- Switching hysteresis max (H): 10%
- Degree of protection: IP67
- Switch status indicator: yellow LED
- Cable conductor cross section: 0,22 mm<sup>2</sup> in diameters 6,5 and 8 mm  
0,35 mm<sup>2</sup> in diameter 12 mm  
0,50 mm<sup>2</sup> in diameters 18 and 30 mm

- Marking: II 3D Ex tc IIIC T80°C IP67 X  
II 3G Ex nAc IIC T6 X

- Protected against short-circuit and overload
- Protected against any wrong connection
- Suppression of initial false impulse
- Electromagnetic compatibility (EMC) according to EN60947-5-2
- According to: EN60079-0/EN60079-15/EN60079-31
- Shock and vibration resistance according to EN60068-2-27/EN60068-2-6



## Use in hazardous area according to instruction manuals

Housing	Flush mounting (*) Non flush mounting	L1	L2	L3	L4	L5	Cable diameter	Body diameter (d)	Supply voltage ( $U_B$ )	Max switching frequency (f)	Rated operational current ( $I_o$ )	Nominal sensing distance ( $S_n$ ) $\pm 10\%$	ORDERING REFERENCES		
		mm	mm	mm	mm	mm							PNP (positive switching)		
B	•	-	40	5	-	45	3,5	M8 x 1	7 ÷ 30	800	200	3		<b>DCE8/4609KS3GD</b>	<b>DCE8/4619KS3GD</b>
B	•	5	35	5	-	45	3,5	M8 x 1	7 ÷ 30	400	200	4		<b>DCE8/5609KS3GD</b>	<b>DCE8/5619KS3GD</b>
B-4	•	-	43	7	-	50	4	M12 x 1	7 ÷ 40	800	200	4		<b>DCE12/4609KS3GD</b>	<b>DCE12/4619KS3GD</b>
B-4	•	7	36	7	-	50	4	M12 x 1	7 ÷ 40	600	200	6		<b>DCE12/5609KS3GD</b>	<b>DCE12/5619KS3GD</b>
B-2	•	-	50	-	-	50	5	M18 x 1	7 ÷ 40	300	200	10		<b>DCE18/4A09KS3GD</b>	<b>DCE18/4A19KS3GD</b>
B-2	•	10	40	-	-	50	5	M18 x 1	7 ÷ 40	200	200	14		<b>DCE18/5A09KS3GD</b>	<b>DCE18/5A19KS3GD</b>
B-5	•	-	50	10	-	60	6	M30 x 1,5	7 ÷ 40	100	200	20		<b>DCE30/4609KS3GD</b>	<b>DCE30/4619KS3GD</b>
B-5	•	15	35	10	-	60	6	M30 x 1,5	7 ÷ 40	100	200	28		<b>DCE30/5609KS3GD</b>	<b>DCE30/5619KS3GD</b>

(\*) Note: See mounting precautions at page 22 of BDC General Catalogue or at this URL: <http://www.bdcelectronic.com/eng/pdfeng/022-024.pdf>

## NPN (negative switching)

Use the above part number changing the last 9 with 8 (ie DCE8/4608KS3GD)

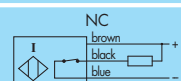
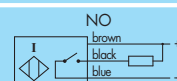



**AMPLIFIED IN d.c. - Extended sensing distance •**  
**ATEX certified II 3GD for zone 2;22 •**  
**Connector output M12x1 •**

**Housing I-11**

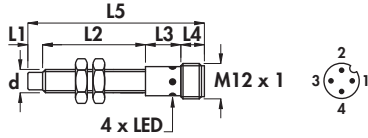

**Housing I-7**

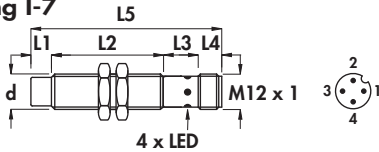

**Housing I-12**

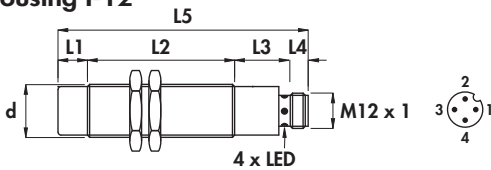

**Housing I-2**

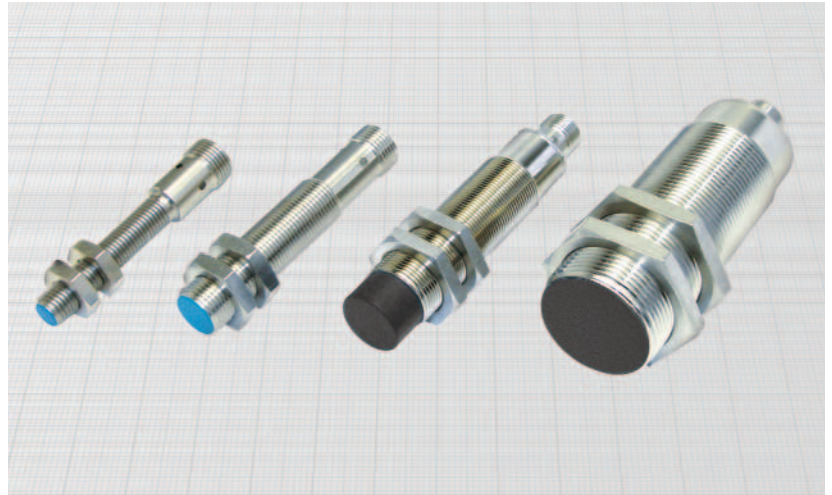
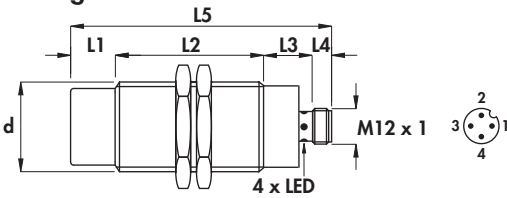

**Technical data:**

- Supply voltage ( $U_B$ ): see ordering references
- Max ripple: 10%
- Rated operational current ( $I_B$ ): 100 mA
- No-load supply current ( $I_o$ ):  $\leq 10$  mA
- Voltage drop ( $U_d$ ):  $\leq 1,5$  V
- Temperature range:  $-25^\circ \text{C} \div +60^\circ \text{C}$
- Max thermal drift of sensing distance  $S_r$ :  $\pm 10\%$
- Repeat accuracy (R): 2%
- Switching hysteresis max (H): 10%
- Degree of protection: IP67
- Switch status indicator: yellow LED
- Marking: II 3D Ex tc IIIC T80°C IP67 X  
II 3G Ex nAc IIC T6 X
- Protected against short-circuit and overload
- Protected against any wrong connection
- Suppression of initial false impulse
- Electromagnetic compatibility (EMC) according to EN60947-5-2
- According to: EN60079-0/EN60079-15/EN60079-31
- Shock and vibration resistance according to EN60068-2-27/EN60068-2-6

Diameter	M8 x 1	M12 x 1	M18 x 1	M30 x 1,5
Nut	Size	SW13	SW17	SW24
	Thickness mm	4	4	4
Max tightening torque Nm	10	15	35	80

**Materials:**

- Housing diameter 8 mm: stainless steel
- Housing diameters 12 - 30 mm: nickel plated brass
- Sensing face: plastic

**Use in hazardous area according to instruction manuals**

Housing	Flush mounting (*) Non flush mounting	L1	L2	L3	L4	L5	Female connector (see page G-1)	Body diameter (d)	Supply voltage ( $U_B$ )	Max switching frequency (f)	Nominal sensing distance ( $S_n$ ) $\pm 10\%$	ORDERING REFERENCES		
												PNP (positive switching)		
												NO	NC	NO + NC
I-11	•	-	40	12	8	60	8B-10	M8 x 1	7 ÷ 30	0,8	3			
I-11	•	5	35	12	8	60	8B-10	M8 x 1	7 ÷ 30	0,4	4	<b>DCE8/4309KS3GD</b>	<b>DCE8/43C9KS3GD</b>	<b>DCE8/4329KS3GD</b>
I-7	•	-	43	15	8	66	8B-10	M12 x 1	7 ÷ 40	0,8	4	<b>DCE12/4309KS3GD</b>	<b>DCE12/43C9KS3GD</b>	<b>DCE12/4329KS3GD</b>
I-7	•	7	36	15	8	66	8B-10	M12 x 1	7 ÷ 40	0,6	6	<b>DCE12/5309KS3GD</b>	<b>DCE12/53C9KS3GD</b>	<b>DCE12/5329KS3GD</b>
I-12	•	-	50	19	8	77	8B-10	M18 x 1	7 ÷ 40	0,3	10	<b>DCE18/4309KS3GD</b>	<b>DCE18/43C9KS3GD</b>	<b>DCE18/4329KS3GD</b>
I-12	•	10	50	19	8	87	8B-10	M18 x 1	7 ÷ 40	0,2	14	<b>DCE18/5309KS3GD</b>	<b>DCE18/53C9KS3GD</b>	<b>DCE18/5329KS3GD</b>
I-2	•	-	65	17	8	90	8B-10	M30 x 1,5	7 ÷ 40	0,1	20	<b>DCE30/4309KS3GD</b>	<b>DCE30/43C9KS3GD</b>	<b>DCE30/4329KS3GD</b>
I-2	•	15	50	17	8	90	8B-10	M30 x 1,5	7 ÷ 40	0,1	28	<b>DCE30/5309KS3GD</b>	<b>DCE30/53C9KS3GD</b>	<b>DCE30/5329KS3GD</b>

(\*) Note: See mounting precautions at page 22 of BDC General Catalogue or at this URL: <http://www.bdcelectronic.com/eng/pdfeng/022-024.pdf>

NPN (negative switching)		
Use the above part number changing the last 9 with 8 (ie DCE8/4308KS3GD)		

# CYLINDRICAL INDUCTIVE ATEX SENSORS IN METAL HOUSING



- **AMPLIFIED IN d.c. 3-wire**
- **SHORT SERIES - Extended sensing distance**
- **ATEX certified II 3GD for zone 2;22**
- Cable output

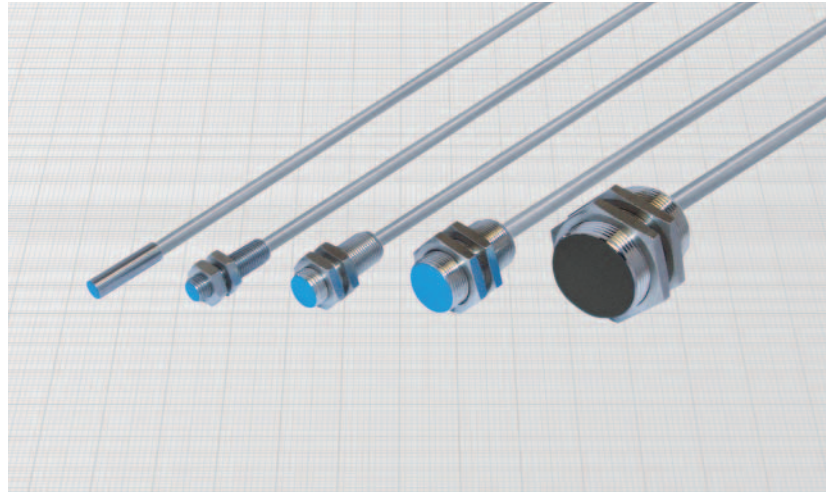
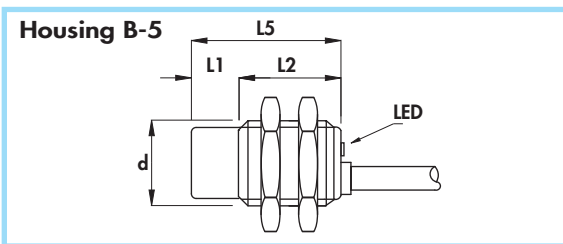
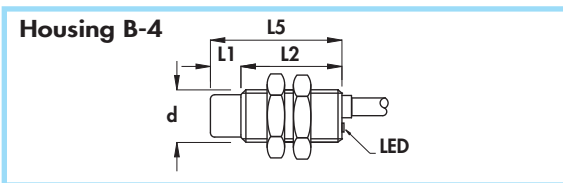
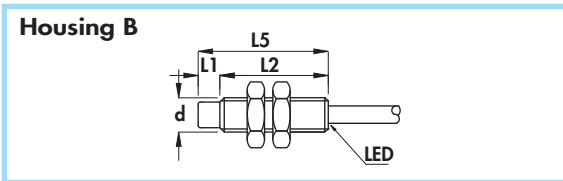
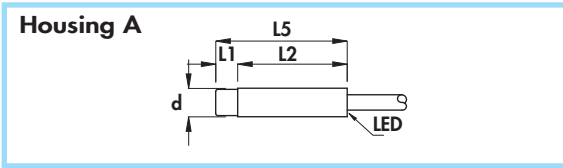

**Technical data:**

- Supply voltage ( $U_b$ ): see ordering references
- Max ripple: 10%
- No-load supply current ( $I_0$ ):  $\leq 10$  mA
- Voltage drop ( $U_d$ ):  $\leq 1,5$  V
- Temperature range:  $-25^\circ \div +60^\circ\text{C}$
- Max thermal drift of sensing distance  $S_s$ :  $\pm 10\%$
- Repeat accuracy (R): 4%
- Switching hysteresis max (H): 10%
- Degree of protection: IP67
- Switch status indicator: yellow LED
- Cable conductor cross section: 0,22 mm<sup>2</sup> in diameters 6,5 and 8 mm  
0,35 mm<sup>2</sup> in diameter 12 mm  
0,50 mm<sup>2</sup> in diameters 18 and 30 mm

Diameter	M8 x 1	M12 x 1	M18 x 1	M30 x 1,5
Nut	Size	SW13	SW17	SW24
	Thickness mm	4	4	4
Max tightening torque Nm	10	15	35	80

- Marking: II 3D Ex tc IIIC T80°C IP67 X  
II 3G Ex nAc IIC T6 X

- Protected against short-circuit and overload
- Protected against any wrong connection
- Suppression of initial false impulse
- Electromagnetic compatibility (EMC) according to EN60947-5-2
- According to: EN60079-0/EN60079-15/EN60079-31
- Shock and vibration resistance according to EN60068-2-27/EN60068-2-6

**Materials:**

- Cable: 2 m PVC CEI 20 - 22 II; 90°C; 300 V; O.R.
- Housing diameters 6,5 and 8 mm: stainless steel
- Housing diameters 12 ÷ 30 mm: nickel plated brass
- Sensing face: plastic

**Use in hazardous area according to instruction manuals**

Housing	Flush mounting (*) Non flush mounting	L1	L2	L3	L4	L5	Cable diameter	Body diameter (d)	Supply voltage ( $U_b$ )	Max switching frequency (f)	Rated operational current ( $I_o$ )	Nominal sensing distance ( $S_n$ ) $\pm 10\%$	ORDERING REFERENCES		
		mm	mm	mm	mm	mm							PNP (positive switching)		
A	•	-	30	-	-	30	3,5	6,5	7 ÷ 30	800	200	3		<b>DSE6,5/4609LKS3GD</b>	<b>DSE6,5/4619LKS3GD</b>
B	•	-	30	-	-	30	3,5	M8 x 1	7 ÷ 30	800	200	3		<b>DSE8/4609KS3GD</b>	<b>DSE8/4619KS3GD</b>
B-4	•	-	30	-	-	30	4	M12 x 1	7 ÷ 30	800	200	4		<b>DSE12/4609KS3GD</b>	<b>DSE12/4619KS3GD</b>
B-4	•	7	23	-	-	30	4	M12 x 1	7 ÷ 30	600	200	6		<b>DSE12/5609KS3GD</b>	<b>DSE12/5619KS3GD</b>
B-5	•	-	35	-	-	35	5	M18 x 1	7 ÷ 40	300	200	10		<b>DSE18/4609KS3GD</b>	<b>DSE18/4619KS3GD</b>
B-5	•	10	25	-	-	35	5	M18 x 1	7 ÷ 40	200	200	14		<b>DSE18/5609KS3GD</b>	<b>DSE18/5619KS3GD</b>
B-5	•	-	35	-	-	35	6	M30 x 1,5	7 ÷ 40	100	200	20		<b>DSE30/4609KS3GD</b>	<b>DSE30/4619KS3GD</b>
B-5	•	15	20	-	-	35	6	M30 x 1,5	7 ÷ 40	100	200	28		<b>DSE30/5609KS3GD</b>	<b>DSE30/5619KS3GD</b>

(\*) Note: See mounting precautions at page 22 of BDC General Catalogue or at this URL: <http://www.bdcelectronic.com/eng/pdfeng/022-024.pdf>

**NPN (negative switching)**  
Use the above part number changing the last 9 with 8 (ie DSE6,5/4608LKS3GD)





**AMPLIFIED IN d.c.** •  
**SHORT SERIES - Extended sensing distance** •  
**ATEX certified II 3GD for zone 2;22** •  
**Connector output M12x1** •

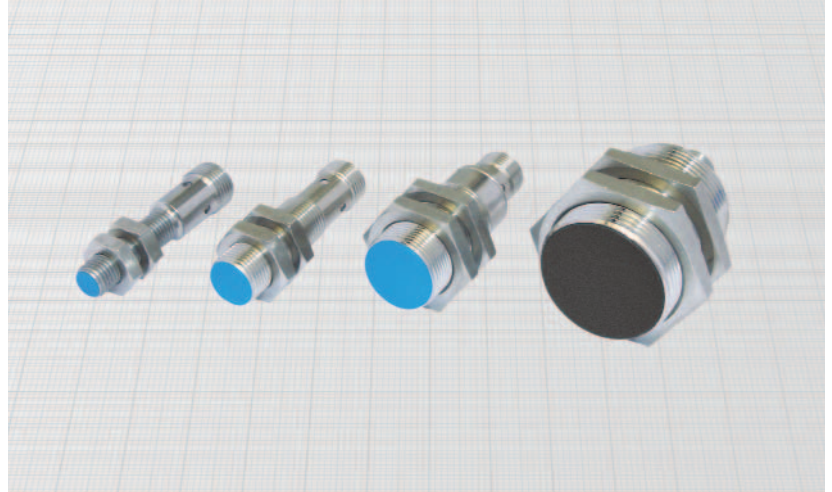
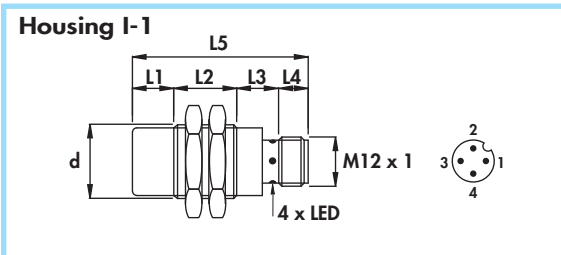
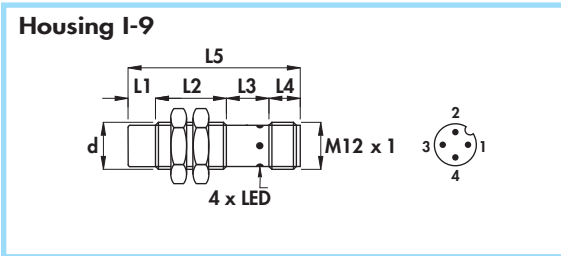
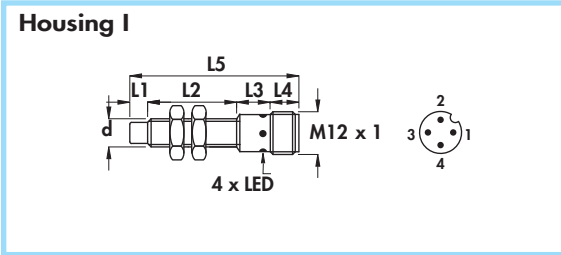

Diameter	M8 x 1	M12 x 1	M18 x 1	M30 x 1,5	
Nut	Size	SW13	SW17	SW24	SW36
	Thickness mm	4	4	4	5
Max tightening torque Nm	10	15	35	80	

**Materials:**

- Housing diameter 8 mm: stainless steel
- Housing diameters 12 ÷ 30 mm: nickel plated brass
- Sensing face: plastic

**Technical data:**

- Supply voltage ( $U_B$ ): see ordering references
- Max ripple: 10%
- Rated operational current ( $I_B$ ): 200 mA
- No-load supply current ( $I_0$ ): ≤ 10 mA
- Voltage drop ( $U_d$ ): ≤ 1,5 V
- Temperature range: -25° ÷ +60°C
- Max thermal drift of sensing distance  $S_T$ : ± 10%
- Repeat accuracy (R): 4%
- Switching hysteresis max (H): 10%
- Degree of protection: IP67
- Switch status indicator: yellow LED
- Marking: II 3D Ex tc IIIC T80°C IP67 X  
II 3G Ex nAc IIC T6 X
- Protected against short-circuit and overload
- Protected against any wrong connection
- Suppression of initial false impulse
- Electromagnetic compatibility (EMC) according to EN60947-5-2
- According to: EN60079-0/EN60079-15/EN60079-31
- Shock and vibration resistance according to EN60068-2-27/EN60068-2-6



**Use in hazardous area according to instruction manuals**

Housing	Flush mounting (*) Non flush mounting	L1	L2	L3	L4	L5	Female connector (see page G-1)	Body diameter (d)	Supply voltage ( $U_B$ )	Max switching frequency (f)	Nominal sensing distance ( $S_T$ ) ±10%	ORDERING REFERENCES			
												PNP (positive switching)			
												NO	NC		
I	•	-	26	13	8	47	6-8B-10	M8 x 1	7 ÷ 30	800	3			<b>DSE8/4309KS3GD</b>	<b>DSE8/43C9KS3GD</b>
I-9	•	-	30	10	8	48	6-8B-10	M12 x 1	7 ÷ 30	800	4	<b>DSE12/4309KS3GD</b>	<b>DSE12/43C9KS3GD</b>	<b>DSE12/4309KS3GD</b>	<b>DSE12/43C9KS3GD</b>
I-9	•	7	23	10	8	48	6-8B-10	M12 x 1	7 ÷ 30	600	6	<b>DSE12/5309KS3GD</b>	<b>DSE12/53C9KS3GD</b>	<b>DSE12/5309KS3GD</b>	<b>DSE12/53C9KS3GD</b>
I-1	•	-	30	19	8	57	6-8B-10	M18 x 1	7 ÷ 40	300	10	<b>DSE18/4309KS3GD</b>	<b>DSE18/43C9KS3GD</b>	<b>DSE18/4309KS3GD</b>	<b>DSE18/43C9KS3GD</b>
I-1	•	10	25	15	8	58	6-8B-10	M18 x 1	7 ÷ 40	200	14	<b>DSE18/5309KS3GD</b>	<b>DSE18/53C9KS3GD</b>	<b>DSE18/5309KS3GD</b>	<b>DSE18/53C9KS3GD</b>
I-1	•	-	25	17	8	50	6-8B-10	M30 x 1,5	7 ÷ 40	100	20	<b>DSE30/4309KS3GD</b>	<b>DSE30/43C9KS3GD</b>	<b>DSE30/4309KS3GD</b>	<b>DSE30/43C9KS3GD</b>
I-1	•	15	25	17	8	65	6-8B-10	M30 x 1,5	7 ÷ 40	100	28	<b>DSE30/5309KS3GD</b>	<b>DSE30/53C9KS3GD</b>	<b>DSE30/5309KS3GD</b>	<b>DSE30/53C9KS3GD</b>

(\*) Note: See mounting precautions at page 22 of BDC General Catalogue or at this URL: <http://www.bdcelectronic.com/eng/pdfeng/022-024.pdf>

**NPN (negative switching)**  
 Use the above part number changing the last 9 with 8 (ie DSE8/4308KS3GD)

NO	NC



# CYLINDRICAL INDUCTIVE ATEX SENSORS IN METAL HOUSING

- **AMPLIFIED IN d.c. 3-wire** - diameters 6,5 - 8 mm
- **ATEX certified II 3GD for zone 2;22**
- **With extended temperature range (-20° ÷ + 80°C)**
- **Cable output**

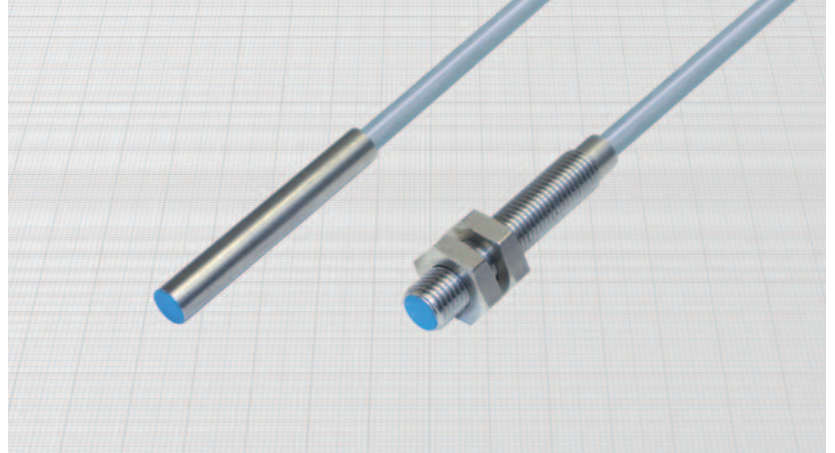
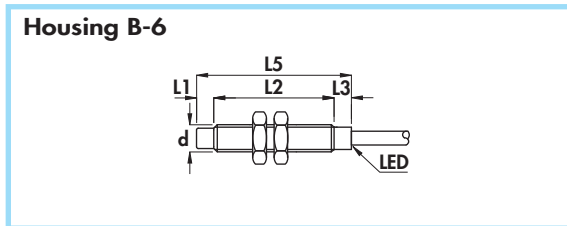
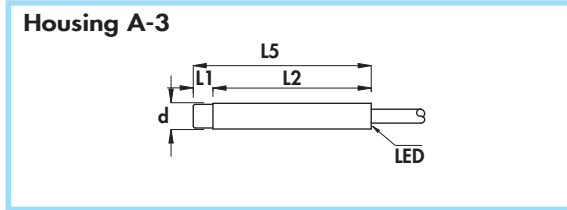

Diameter	M8 x 1	
Nut	Size	SW13
	Thickness mm	4
Max tightening torque Nm	10	

**Materials:**

- Cable: 2 m PVC; 105° C; 300 V; O.R.
- Housing: stainless steel
- Sensing face: plastic

**Technical data:**

- Supply voltage ( $U_B$ ): 7 ÷ 30 Vdc
- Max ripple: 10%
- No-load supply current ( $I_0$ ): ≤ 10 mA
- Voltage drop ( $U_d$ ): < 1,5 V
- Temperature range: -25° ÷ + 80°C
- Max thermal drift of sensing distance  $S_r$ : ± 10%
- Repeat accuracy (R): 2%
- Switching hysteresis max (H): 10%
- Degree of protection: IP67
- Switch status indicator: yellow LED
- Cable conductor cross section: 0,35 mm<sup>2</sup>
- Marking: II 3D Ex tc IIIC T100°C IP67 X  
II 3G Ex nAc IIC T5 X
- Protected against short-circuit and overload
- Protected against any wrong connection
- Suppression of initial false impulse
- Electromagnetic compatibility (EMC) according to EN60947-5-2
- According to: EN60079-0/EN60079-15/EN60079-31
- Shock and vibration resistance according to EN60068-2-27/EN60068-2-6

**Use in hazardous area according to instruction manuals**

Housing	Mounting	L1	L2	L3	L5	Cable diameter	Body diameter (d)	Max switching frequency (f)	Rated operational current (I <sub>o</sub> )	Nominal sensing distance (S <sub>n</sub> ) ±10%	ORDERING REFERENCES	
											PNP (positive switching)	
A-3	Flush mounting	-	45	-	45	4	6,5	4	50	1,5		
A-3	Non flush mounting	5	40	-	45	4	6,5	3	50	2,5	<b>DCA6,5/4609LKST3GD</b> <b>DCA6,5/5609LKST3GD</b>	<b>DCA6,5/4619LKST3GD</b> <b>DCA6,5/5619LKST3GD</b>
B-6	Flush mounting	-	40	5	45	4	M8 x 1	4	50	1,5		
B-6	Non flush mounting	5	35	5	45	4	M8 x 1	3	50	2,5	<b>DCA8/4609KST3GD</b> <b>DCA8/5609KST3GD</b>	<b>DCA8/4619KST3GD</b> <b>DCA8/5619KST3GD</b>
<b>NPN (negative switching)</b>												
Use the above part number changing the last 9 with 8 (ie DCA6,5/4608LKST3GD)												



**AMPLIFIED IN d.c. 3-wire - diameter 12 mm** •  
**ATEX certified II 3GD for zone 2;22** •  
**With extended temperature range (-20° ÷ + 80°C)** •  
**Cable output** •

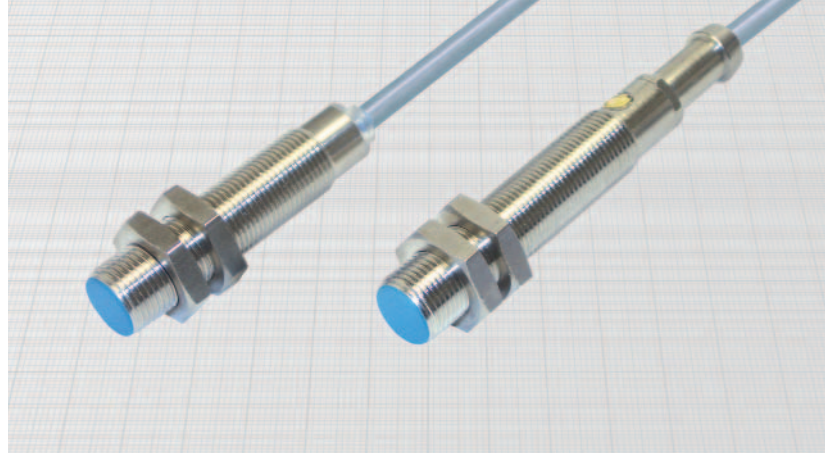
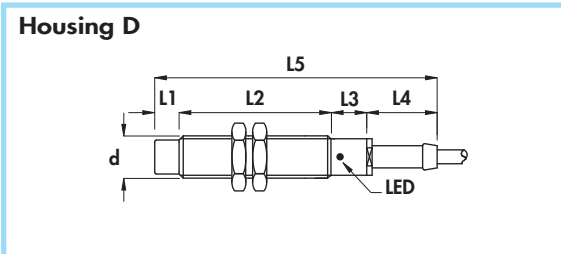
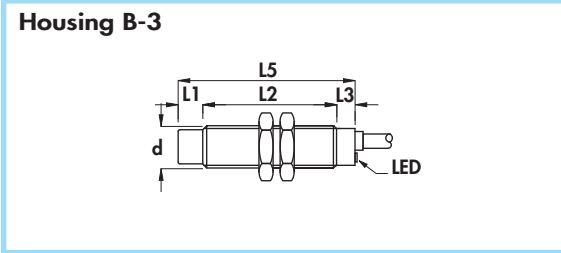

Diameter	M12 x 1	
Nut	Size	SW17
	Thickness mm	4
Max tightening torque Nm	15	

**Materials:**

- Cable: 2 m PVC; 105° C; 300 V; O.R.
- Housing: nickel plated brass
- Sensing face: plastic

**Technical data:**

- Supply voltage ( $U_B$ ): 5 ÷ 40 Vdc
- Max ripple: 10%
- No-load supply current ( $I_o$ ): ≤ 10 mA
- Voltage drop ( $U_d$ ): < 1,5 V
- Temperature range: -20° ÷ + 80°C
- Max thermal drift of sensing distance  $S_r$ : ± 10%
- Repeat accuracy (R): 2%
- Switching hysteresis max (H): 10%
- Degree of protection: IP67
- Switch status indicator: yellow LED
- Cable conductor cross section: 0,35 mm<sup>2</sup>
- Marking: II 3D Ex tc IIIC T100°C IP67 X  
II 3G Ex nAc IIC T5 X

- Protected against short-circuit and overload
- Protected against any wrong connection
- Suppression of initial false impulse
- Electromagnetic compatibility (EMC) according to EN60947-5-2
- According to: EN60079-0/EN60079-15/EN60079-31
- Shock and vibration resistance according to EN60068-2-27/EN60068-2-6

**Use in hazardous area according to instruction manuals**

Housing	Flush mounting Non flush mounting	L1	L2	L3	L4	L5	Cable diameter	Body diameter (d)	Max switching frequency (f)	Rated operational current ( $I_e$ )	Nominal sensing distance ( $S_n$ ) ±10%	ORDERING REFERENCES	
												mm	mm
B-3	•	-	43	7	-	50	4	M12 x 1	2	50	2	<b>PNP (positive switching)</b>	
D	•	-	50	10	20	80	4	M12 x 1	2	50	2		
B-3	•	7	36	7	-	50	4	M12 x 1	1,5	50	4	<b>DCA12/4609KST3GD</b> <b>DCA12/4709KST3GD</b> <b>DCA12/5609KST3GD</b> <b>DCA12/5709KST3GD</b>	
D	•	7	43	10	20	80	4	M12 x 1	1,5	50	4	<b>DCA12/4619KST3GD</b> <b>DCA12/4719KST3GD</b> <b>DCA12/5619KST3GD</b> <b>DCA12/5719KST3GD</b>	
												<b>NPN (negative switching)</b>	
												Use the above part number changing the last 9 with 8 (ie DCA12/4608KST3GD)	

# CYLINDRICAL INDUCTIVE ATEX SENSORS IN METAL HOUSING

- **AMPLIFIED IN d.c. 3 and 4-wires** - diameters 18 - 30 - 45 mm
- **ATEX certified II 3GD for zone 2;22**
- **With extended temperature range (-20° ÷ + 80°C)**
- **Cable output**

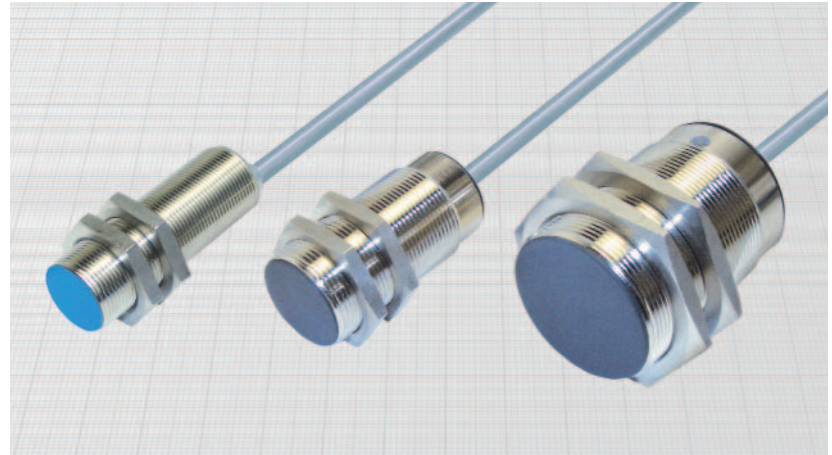
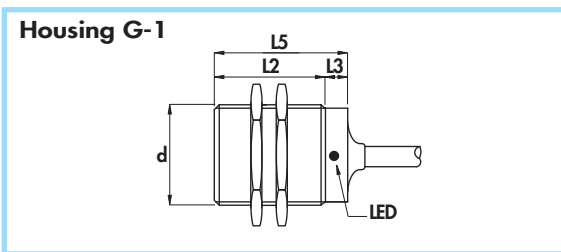
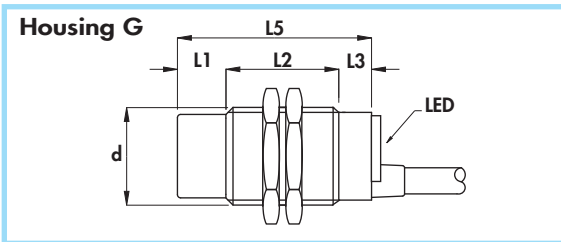
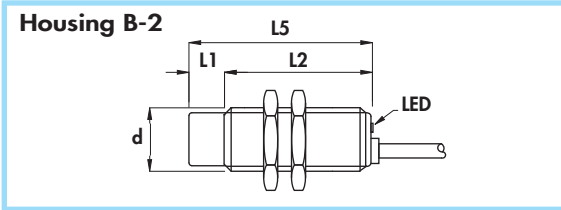

Diameter	M18 x 1	M30 x 1,5	M45 x 1,5
Nut	Size SW24	SW36	SW55
	Thickness mm 4	8	5
Max tightening torque Nm	35	80	70

### Materials:

- Cable: 2 m PVC; 105° C; 300 V; O.R.
- Housing: nickel plated brass
- Sensing face: plastic

### Technical data:

- Supply voltage ( $U_B$ ): diameter 18 mm: 5 ÷ 30 Vdc  
diameters 30 - 45 mm: 10 ÷ 30 Vdc
- Max ripple: 10%
- No-load supply current ( $I_0$ ): ≤ 10 mA
- Voltage drop ( $U_d$ ): < 2,2 V
- Temperature range: -25° ÷ + 80°C
- Max thermal drift of sensing distance  $S_r$ : ± 10%
- Repeat accuracy (R): 2%
- Switching hysteresis max (H): 10%
- Degree of protection: IP67
- Switch status indicator: yellow LED
- Cable conductor cross section: 0,50 mm<sup>2</sup> in 3-wire version diameter 18 mm  
0,35 mm<sup>2</sup> in 4-wire version diameter 18 mm  
0,50 mm<sup>2</sup> for diameters 30 and 45 mm
- Marking: II 3D Ex tc IIIC T100°C IP67 X  
II 3G Ex nAc IIC T5 X
- Protected against short-circuit and overload
- Protected against any wrong connection
- Suppression of initial false impulse
- Electromagnetic compatibility (EMC) according to EN60947-5-2
- According to: EN60079-0/EN60079-15/EN60079-31
- Shock and vibration resistance according to EN60068-2-27/EN60068-2-6

### Use in hazardous area according to instruction manuals

Housing	Flush mounting Non flush mounting	L1	L2	L3	L4	L5	Cable diameter	Body diameter (d)	Max switching frequency (f)	Rated operational current ( $I_0$ )	Nominal sensing distance ( $S_n$ ) ± 10%	ORDERING REFERENCES		
												PNP (positive switching)		
B - 2	•	-	50	-	-	50	5	M18 x 1	1	50	5	DCA18/4A09KST3GD	DCA18/4A19KST3GD	DCA18/4A29KST3GD
B - 2	•	10	40	-	-	50	5	M18 x 1	1	50	8	DCA18/5A09KST3GD	DCA18/5A19KST3GD	DCA18/5A29KST3GD
G	•	-	50	10	-	60	6	M30 x 1,5	0,8	50	10	DCA30/4609KST3GD	DCA30/4619KST3GD	DCA30/4629KST3GD
G	•	15	35	10	-	90	6	M30 x 1,5	0,4	50	15	DCA30/5609KST3GD	DCA30/5619KST3GD	DCA30/5629KST3GD
G - 1	•	10	50	10	-	60	6	M45 x 1,5	0,15	50	20	DCA45/4609KST3GD	DCA45/4619KST3GD	DCA45/4629KST3GD
												NPN (negative switching)		
												Use the above part number changing the last 9 with 8 (ie DCA18/4A08KST3GD)		



**AMPLIFIED IN d.c.** •  
**ATEX certified II 3GD for zone 2;22** •  
**With extended temperature range (-20° ÷ + 80°C)** •  
**Connector output M12x1** •

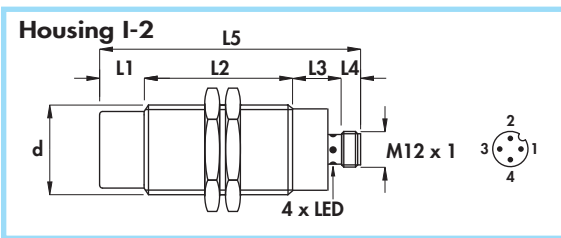
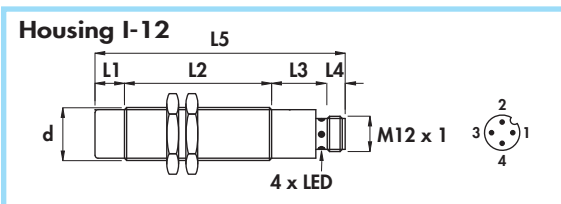
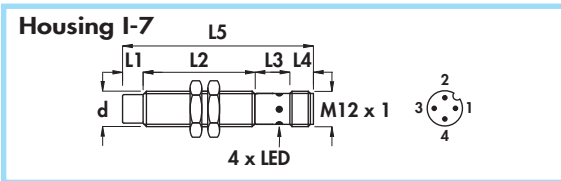
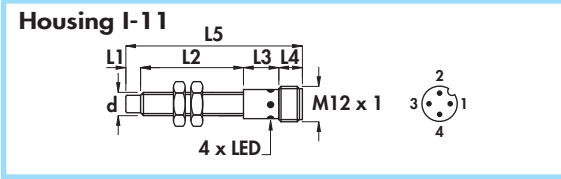

Diameter	M8 x 1	M12 x 1	M18 x 1	M30 x 1,5
Nut	Size	SW13	SW17	SW24
	Thickness mm	4	4	4
Max tightening torque Nm	10	15	35	80

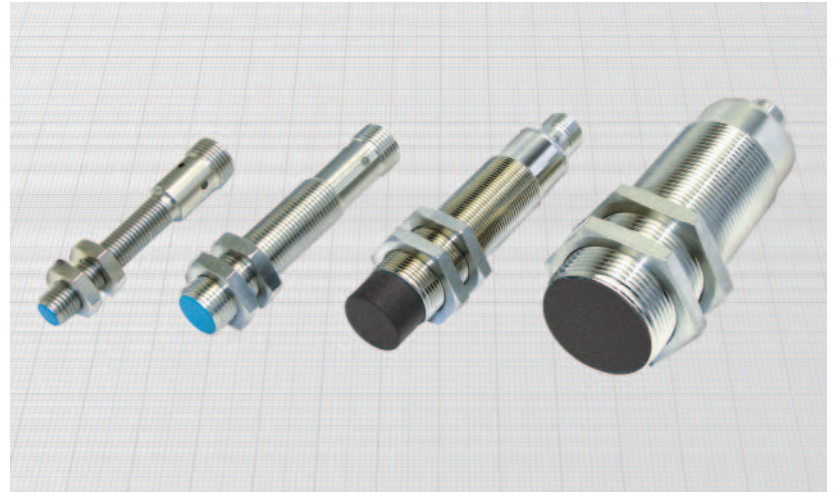

**Technical data:**

- Supply voltage ( $U_B$ ): 10 ÷ 30 Vdc
- Max ripple: 10%
- Rated operational current ( $I_B$ ): ≤ 50 mA
- No-load supply current ( $I_0$ ): ≤ 10 mA
- Voltage drop ( $U_d$ ): < 1,5 V
- Temperature range: -25° ÷ + 80°C
- Max thermal drift of sensing distance  $S_r$ : ± 10%
- Repeat accuracy (R): 2%
- Switching hysteresis max (H): 10%
- Degree of protection: IP67
- Marking: II 3D Ex tc IIC T100°C IP67 X  
II 3G Ex nAc IIC T5 X

- Protected against short-circuit and overload
- Protected against any wrong connection
- Suppression of initial false impulse
- Electromagnetic compatibility (EMC) according to EN60947-5-2
- According to: EN60079-0/EN60079-15/EN60079-31
- Shock and vibration resistance according to EN60068-2-27/EN60068-2-6

**Materials:**

- Housing diameter 8 mm: stainless steel
- Housing diameters 12- 18 - 30 mm: nickel plated brass
- Sensing face: plastic

**Use in hazardous area according to instruction manuals**

Housing	Flush mounting Non flush mounting	L1	L2	L3	L4	L5	Female connector (see. page G-1)	Body diameter (d)	Max switching frequency (f)	Nominal sensing distance ( $S_n$ ) ± 10%	ORDERING REFERENCES			
											PNP (positive switching)			
											NO	NC	NO + NC	
I-11	•	-	40	12	8	60	8B-10	M8 x 1	4	1,5				
I-11	•	5	35	12	8	60	8B-10	M8 x 1	3	2,5	<b>DCA8/4309KST3GD</b>	<b>DCA8/43C9KST3GD</b>	-	
											<b>DCA8/5309KST3GD</b>	<b>DCA8/53C9KST3GD</b>	-	
I-7	•	-	43	15	8	66	8B-10	M12 x 1	2	2				
I-7	•	7	36	15	8	66	8B-10	M12 x 1	1,5	4	<b>DCA12/4309KST3GD</b>	<b>DCA12/43C9KST3GD</b>	-	
											<b>DCA12/5309KST3GD</b>	<b>DCA12/53C9KST3GD</b>	-	
I-12	•	-	50	19	8	77	8B-10	M18 x 1	1	5				
I-12	•	10	50	19	8	87	8B-10	M18 x 1	1	8	<b>DCA18/4309KST3GD</b>	<b>DCA18/43C9KST3GD</b>	<b>DCA18/4329KST3GD</b>	
											<b>DCA18/5309KST3GD</b>	<b>DCA18/53C9KST3GD</b>	<b>DCA18/5329KST3GD</b>	
I-2	•	-	65	17	8	90	8B-10	M30 x 1,5	0,8	10				
I-2	•	15	50	17	8	90	8B-10	M30 x 1,5	0,4	15	<b>DCA30/4309KST3GD</b>	<b>DCA30/43C9KST3GD</b>	<b>DCA30/4329KST3GD</b>	
											<b>DCA30/5309KST3GD</b>	<b>DCA30/53C9KST3GD</b>	<b>DCA30/5329KST3GD</b>	
												NPN (negative switching)		
Use the above part number changing the last 9 with 8 (ie DCA8/4308KST3GD)														

# CYLINDRICAL INDUCTIVE ATEX SENSORS IN METAL HOUSING

- **AMPLIFIED IN d.c. 3 and 4-wires - diameters 6,5 - 8 mm**
- **ATEX certified II 3GD for zone 2;22**
- **For high temperatures with LED (-20° ÷ + 100°C)**
- **Cable output**

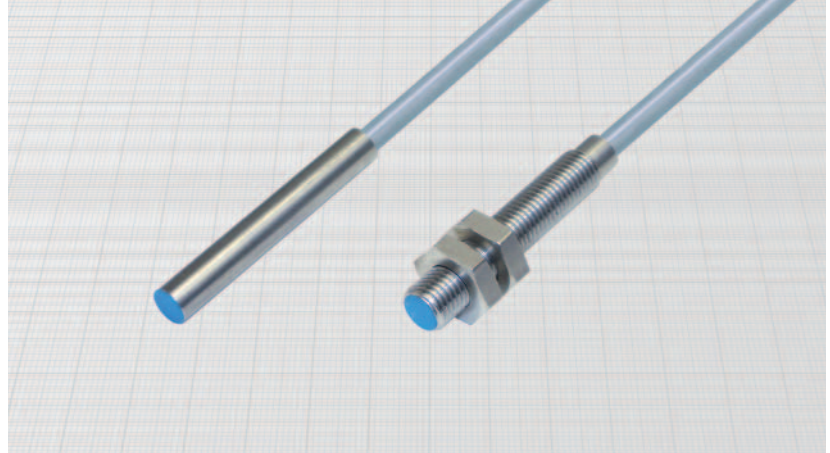
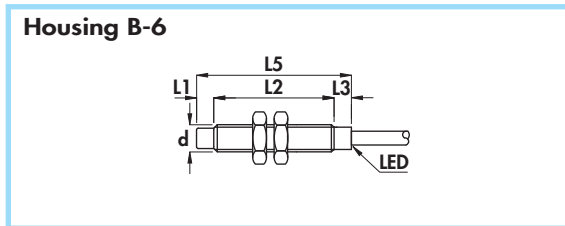
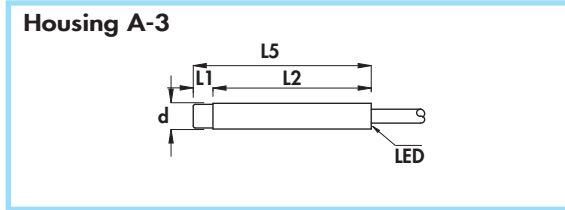

Diameter	M8 x 1	
Nut	Size	SW13
	Thickness mm	4
Max tightening torque Nm	10	

**Materials:**

- Cable: 2 m Thermoplastic; 140°C; 300 V; O.R.
- Housing: stainless steel
- Sensing face: plastic

**Technical data:**

- Supply voltage ( $U_b$ ): 7 ÷ 30 Vdc
- Max ripple: 10%
- No-load supply current ( $I_0$ ): ≤ 10 mA
- Voltage drop ( $U_d$ ): < 1,5 V
- Temperature range: - 25° ÷ + 100°C
- Max thermal drift of sensing distance  $S_r$ : ± 10%
- Repeat accuracy (R): 2%
- Switching hysteresis max (H): 10%
- Degree of protection: IP67
- Switch status indicator: yellow LED
- Cable conductor cross section: 0,35 mm<sup>2</sup>
- Marking: II 3D Ex tc IIIC T1 20°C IP67 X  
II 3G Ex nAc IIC T4 X
- Protected against short-circuit and overload
- Protected against any wrong connection
- Suppression of initial false impulse
- Electromagnetic compatibility (EMC) according to EN60947-5-2
- According to: EN60079-0/EN60079-15/EN60079-31
- Shock and vibration resistance according to EN60068-2-27/EN60068-2-6

Use in hazardous area according to instruction manuals

Housing	Flush mounting Non flush mounting	L1	L2	L3	L5	Cable diameter	Body diameter (d)	Max switching frequency (f)	Rated operational current ( $I_e$ )	Nominal sensing distance ( $S_n$ ) ± 10%	ORDERING REFERENCES	
											PNP (positive switching)	
A-3	•	-	45	-	45	3,5	6,5	4	50	1,5		
A-3	•	5	40	-	45	3,5	6,5	3	50	2,5	<b>DCA6,5/4609LKSTB3GD</b> <b>DCA6,5/5609LKSTB3GD</b>	<b>DCA6,5/4619LKSTB3GD</b> <b>DCA6,5/5619LKSTB3GD</b>
B-6	•	-	40	5	45	3,5	M8 x 1	4	50	1,5		
B-6	•	5	35	5	45	3,5	M8 x 1	3	50	2,5	<b>DCA8/4609KSTB3GD</b> <b>DCA8/5609KSTB3GD</b>	<b>DCA8/4619KSTB3GD</b> <b>DCA8/5619KSTB3GD</b>
<b>NPN (negative switching)</b>												
Use the above part number changing the last 9 with 8 (ie DCA6,5/4608LKSTB3GD)												



**AMPLIFIED IN d.c. 3-wire - diameter 12 mm •**  
**ATEX certified II 3GD for zone 2;22 •**  
**For high temperatures with LED (-20° ÷ + 100°C) •**  
**Cable output •**

**Housing B-3**

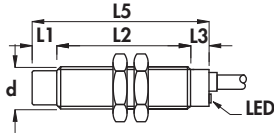

Diameter	M12 x 1	
Nut	Size	SW17
	Thickness mm	4
Max tightening torque Nm	15	

**Materials:**

- Cable: 2 m Thermoplastic; 140°C; 300 V; O.R.
- Housing: nickel plated brass
- Sensing face: plastic

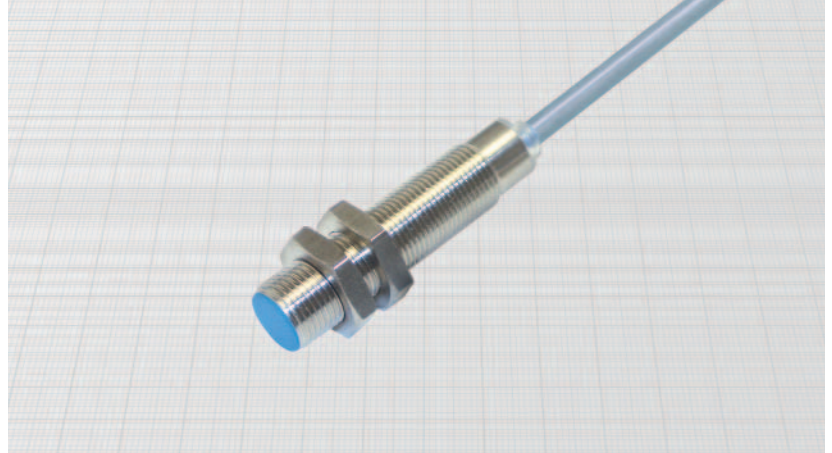

**Technical data:**

- Supply voltage ( $U_b$ ): 5 ÷ 40 Vdc
- Max ripple: 10%
- No-load supply current ( $I_o$ ): ≤ 10 mA
- Voltage drop ( $U_d$ ): < 1,5 V
- Temperature range: - 25° ÷ + 100°C
- Max thermal drift of sensing distance  $S_r$ : ± 10%
- Repeat accuracy (R): 2%
- Switching hysteresis max (H): 10%
- Degree of protection: IP67
- Switch status indicator: yellow LED
- Cable conductor cross section: 0,35 mm<sup>2</sup>
- Marking: II 3D Ex tc IIIC T120°C IP67 X  
II 3G Ex nAc IIC T4 X
- Protected against short-circuit and overload
- Protected against any wrong connection
- Suppression of initial false impulse
- Electromagnetic compatibility (EMC) according to EN60947-5-2
- According to: EN60079-0/EN60079-15/EN60079-31
- Shock and vibration resistance according to EN60068-2-27/EN60068-2-6

Use in hazardous area according to instruction manuals

Housing	Flush mounting Non flush mounting	L1	L2	L3	L4	L5	Cable diameter	Body diameter (d)	Max switching frequency (f)	Rated operational current (I <sub>e</sub> )	Nominal sensing distance (S <sub>N</sub> ) ±10%	ORDERING REFERENCES	
												PNP (positive switching)	
B-3	•	-	43	7	-	50	4	M12 x 1	2	50	2	NO brown black blue	NC brown black blue
B-3	•	7	36	7	-	50	4	M12 x 1	1,5	50	4	DCA12/4609KSTB3GD	DCA12/4619KSTB3GD
												DCA12/5609KSTB3GD	DCA12/5619KSTB3GD
												NPN (negative switching)	
												Use the above part number changing the last 9 with 8 (ie DCA12/4608KSTB3GD)	
												NO brown black blue	NC brown black blue

# CYLINDRICAL INDUCTIVE ATEX SENSORS IN METAL HOUSING

- **AMPLIFIED IN d.c. 3 and 4-wires - diameter 18 - 30 - 45 mm**
- **ATEX certified II 3GD for zone 2;22**
- **For high temperatures with LED (-20° ÷ + 100°C)**
- **Cable output**

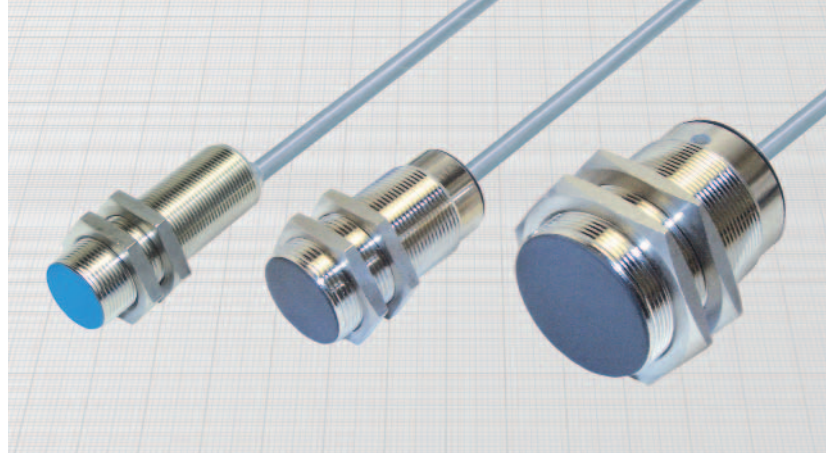
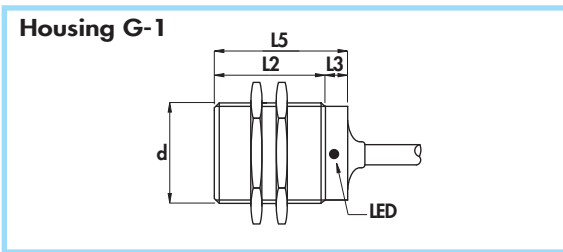
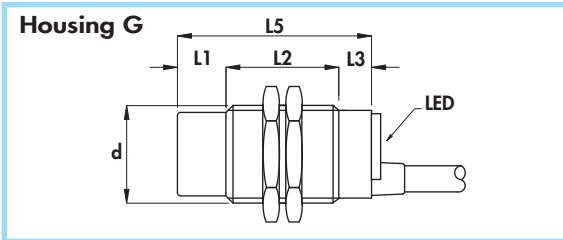
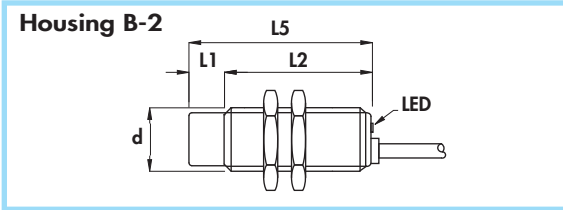

Diameter	M18 x 1	M30 x 1,5	M45 x 1,5
Nut	Size SW24	SW36	SW55
	Thickness mm 4	5	5
Max tightening torque Nm	35	80	70

### Materials:

- Cable: 2 m Thermoplastic; 140° C; 300 V; O.R.
- Housing: nickel plated brass
- Sensing face: plastic

### Technical data:

- Supply voltage ( $U_B$ ): diameter 18 mm: 5 ÷ 30 Vdc  
diameters 30 - 45 mm: 10 ÷ 30 Vdc
- Max ripple: 10%
- No-load supply current ( $I_0$ ): ≤ 10 mA
- Voltage drop ( $U_d$ ): < 2,2 V
- Temperature range: -25° ÷ + 100°C
- Max thermal drift of sensing distance  $S_r$ : ± 10%
- Repeat accuracy (R): 2%
- Switching hysteresis max (H): 10%
- Degree of protection: IP67
- Switch status indicator: yellow LED
- Cable conductor cross section: 0,50 mm<sup>2</sup> in 3-wire version diameter 18 mm  
0,35 mm<sup>2</sup> in 4-wire version diameter 18 mm  
0,50 mm<sup>2</sup> in diameters 30 and 45 mm
- Marking: II 3D Ex tc IIIC T120°C IP67 X  
II 3G Ex nAc IIC T4 X
- Protected against short-circuit and overload
- Protected against any wrong connection
- Suppression of initial false impulse
- Electromagnetic compatibility (EMC) according to EN60947-5-2
- According to: EN60079-0/EN60079-15/EN60079-31
- Shock and vibration resistance according to EN60068-2-27/EN60068-2-6

Use in hazardous area according to instruction manuals

Housing	Flush mounting Non flush mounting	L1	L2	L3	L5	Cable diameter	Body diameter (d)	Max switching frequency (f)	Rated operational current (I <sub>o</sub> )	Nominal sensing distance (S <sub>d</sub> ) ± 10%	ORDERING REFERENCES		
											PNP (positive switching)		
B - 2	•	-	50	-	50	5	M18 x 1	1	50	5	DCA18/4A09KSTB3GD	DCA18/4A19KSTB3GD	DCA18/4A29KSTB3GD
B - 2	•	10	40	-	50	5	M18 x 1	1	50	8	DCA18/5A09KSTB3GD	DCA18/5A19KSTB3GD	DCA18/5A29KSTB3GD
G	•	-	50	10	60	6	M30 x 1,5	0,8	50	10	DCA30/4609KSTB3GD	DCA30/4619KSTB3GD	DCA30/4629KSTB3GD
G	•	15	35	10	90	6	M30 x 1,5	0,4	50	15	DCA30/5609KSTB3GD	DCA30/5619KSTB3GD	DCA30/5629KSTB3GD
G - 1	•	10	50	10	60	6	M45 x 1,5	0,15	50	20	DCA45/4609KSTB3GD	DCA45/4619KSTB3GD	DCA45/4629KSTB3GD
											NPN (negative switching)		
											Use the above part number changing the last 9 with 8 (ie DCA18/4A08KSTB3GD)		



**AMPLIFIED IN d.c.** •  
**ATEX certified II 3GD for zone 2;22** •  
**For high temperatures with LED (-20° ÷ + 100°C)** •  
**Connector output M12x1** •

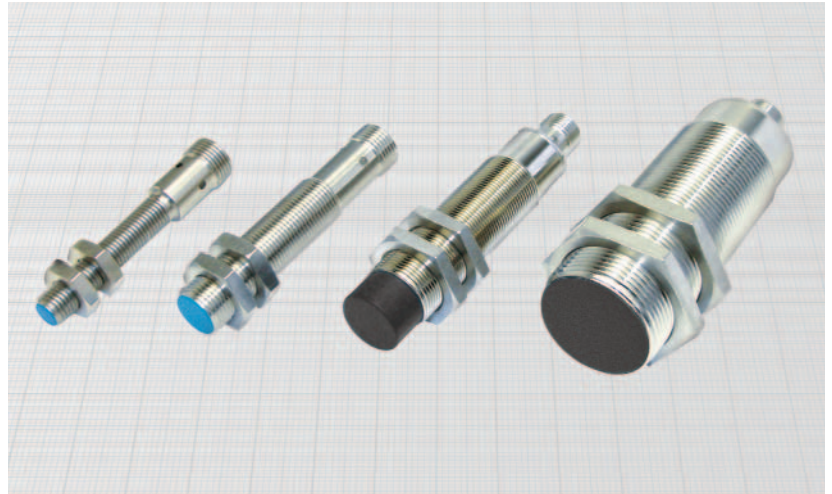
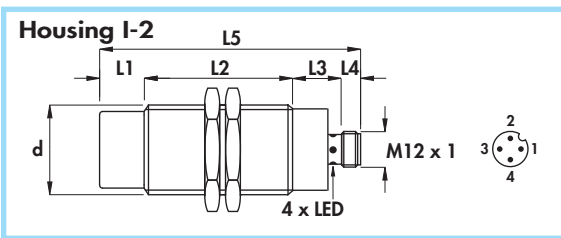
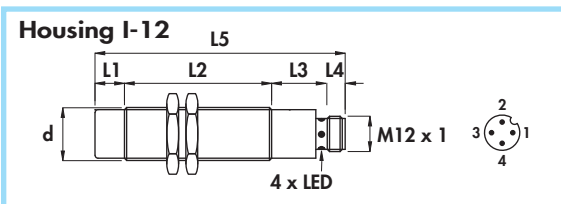
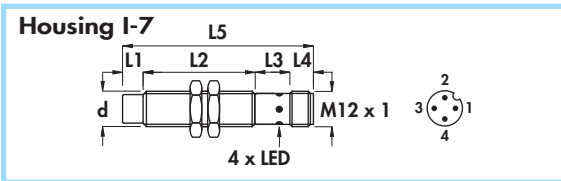
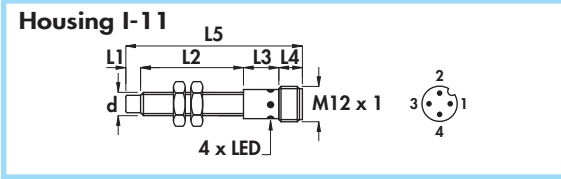

Diameter	M8 x 1	M12 x 1	M18 x 1	M30 x 1,5	
Nut	Size	SW13	SW17	SW24	SW36
	Thickness mm	4	4	4	5
Max tightening torque Nm	10	15	35	80	

**Technical data:**

- Supply voltage ( $U_B$ ): 10 ÷ 30 Vdc
- Max ripple: 10%
- Rated operational current ( $I_B$ ): ≤ 50 mA
- No-load supply current ( $I_0$ ): ≤ 10 mA
- Voltage drop ( $U_U$ ): < 1,5 V
- Temperature range: -25° ÷ + 100°C
- Max thermal drift of sensing distance  $S_T$ : ± 10%
- Repeat accuracy (R): 2%
- Switching hysteresis max (H): 10%
- Degree of protection: IP67
- Marking: II 3D Ex tc IIC T120°C IP67 X  
II 3G Ex nAc IIC T4 X

- Protected against short-circuit and overload
- Protected against any wrong connection
- Suppression of initial false impulse
- Electromagnetic compatibility (EMC) according to EN60947-5-2
- According to: EN60079-0/EN60079-15/EN60079-31
- Shock and vibration resistance according to EN60068-2-27/EN60068-2-6

**Materials:**

- Housing diameter 8 mm: stainless steel
- Housing diameters 12- 18 - 30 mm: nickel plated brass
- Sensing face: plastic

**Use in hazardous area according to instruction manuals**

Housing	Flush mounting Non flush mounting	L1	L2	L3	L4	L5	Female connector (see page G - 1)	Body diameter (d)	Max switching frequency (f)	Nominal sensing distance ( $S_n$ ) ± 10%	ORDERING REFERENCES		
											PNP (positive switching)		
											NO	NC	NO + NC
I-11	•	-	40	12	8	60	8B-10	M8 x 1	4	1,5			
I-11	•	5	35	12	8	60	8B-10	M8 x 1	3	2,5			
I-7	•	-	43	15	8	66	8B-10	M12 x 1	2	2			
I-7	•	7	36	15	8	66	8B-10	M12 x 1	1,5	4			
I-12	•	-	50	19	8	77	8B-10	M18 x 1	1	5			
I-12	•	10	50	19	8	87	8B-10	M18 x 1	1	8			
I-2	•	-	65	17	8	90	8B-10	M30 x 1,5	0,8	10			
I-2	•	15	50	17	8	90	8B-10	M30 x 1,5	0,4	15			
<b>NPN (negative switching)</b>													
Use the above part number changing the last 9 with 8 (ie DCA8/4308KSTB3GD)													



# CYLINDRICAL INDUCTIVE ATEX SENSORS IN METAL HOUSING

- **AMPLIFIED IN d.c. + a.c. 2-wires - Voltage 10 ÷ 50 V $\approx$**
- **ATEX certified II 3GD for zone 2;22**
- Cable output

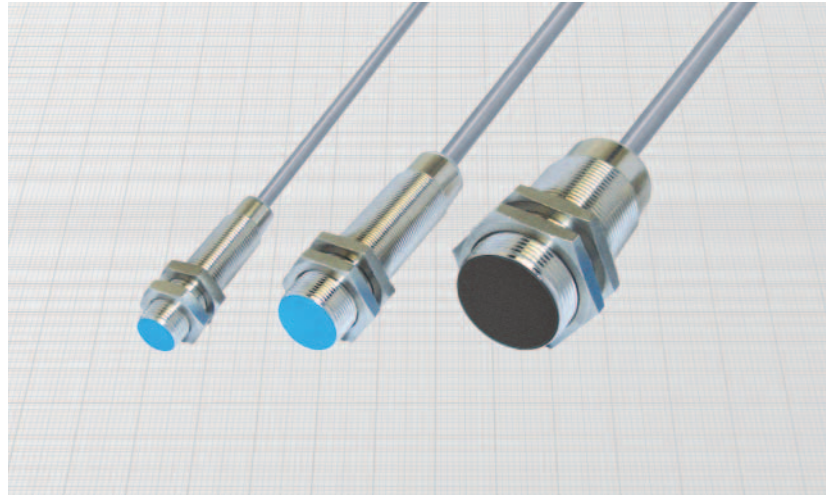
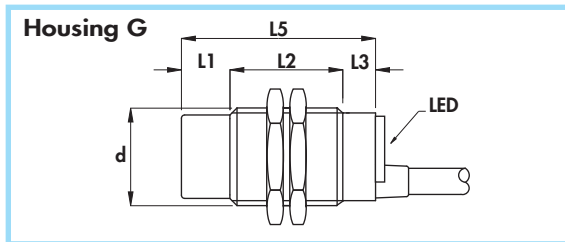
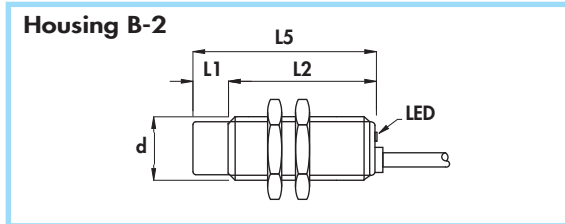
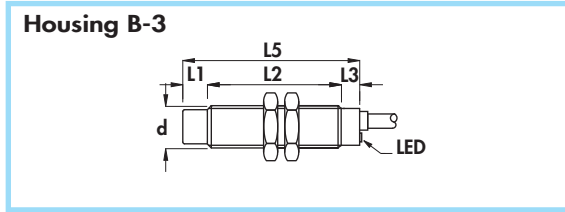

Diameter	M12 x 1	M18 x 1	M30 x 1,5
Nut	Size	SW17	SW24
	Thickness mm	4	4
Max tightening torque Nm	15	35	80

### Materials:

- Cable: 2 m PVC CEI 20 - 22 II; 90°C; 300 V; O.R.
- Housing: nickel plated brass
- Sensing face: plastic

### General features:

These sensors are able to work with either direct or alternating current. Voltage drop and residual current are very low. They are not polarized and the load can be connected either of the leads. In many applications they can be used to replace mechanical microswitches.

### Technical data:

- Supply voltage ( $U_B$ ): 10 ÷ 50 Vdc/Vac
- Electrical system frequency: 40 ÷ 60 Hz
- Off-state current ( $I_o$ ): ≤ 1 mA
- Minimum operational current ( $I_m$ ): 5 mA
- Voltage drop ( $U_d$ ): ≤ 5 V
- Temperature range: -25° ÷ +60°C
- Max thermal drift of sensing distance  $S_p$ : ± 10%
- Repeat accuracy (R): 2%
- Switching hysteresis max (H): 10%
- Degree of protection: IP67
- Switch status indicator: yellow LED
- Cable conductor cross section: 0,35 mm<sup>2</sup> in diameter 12 mm  
0,50 mm<sup>2</sup> in diameter 18 mm  
0,75 mm<sup>2</sup> in diameter 30 mm

- Marking: II 3D Ex tc IIIC T80°C IP67 X  
II 3G Ex nAc IIC T6 X

- Protected against short-circuit and overload
- Suppression of initial false impulse
- Electromagnetic compatibility (EMC) according to EN60947-5-2
- According to: EN60079-0/EN60079-15/EN60079-31
- Shock and vibration resistance according to EN60068-2-27/EN60068-2-6

### Use in hazardous area according to instruction manuals

Housing	Flush mounting Non flush mounting	L1	L2	L3	L4	L5	Cable diameter	Body diameter (d)	Max switching frequency (f) in d.c.	Max switching frequency (f) in a.c.	Rated operational current (I <sub>e</sub> )	Nominal sensing distance (S <sub>n</sub> ) ± 10%	ORDERING REFERENCES	
		mm	mm	mm	mm	mm								
B-3	•	-	43	7	-	50	4	M12 x 1	800	25	100	2	<b>AXM12/4600KS3GD</b>	<b>AXM12/4610KS3GD</b>
B-3	•	7	36	7	-	50	4	M12 x 1	600	25	100	4	<b>AXM12/5600KS3GD</b>	<b>AXM12/5610KS3GD</b>
B-2	•	-	58	12	-	70	5	M18 x 1	800	25	200	5	<b>AXM18/4A00KS3GD</b>	<b>AXM18/4A10KS3GD</b>
B-2	•	10	48	12	-	70	5	M18 x 1	400	25	200	8	<b>AXM18/5A00KS3GD</b>	<b>AXM18/5A10KS3GD</b>
G	•	-	50	10	-	60	6	M30 x 1,5	400	25	200	10	<b>AXM30/4600KS3GD</b>	<b>AXM30/4610KS3GD</b>
G	•	15	35	10	-	60	6	M30 x 1,5	200	25	200	15	<b>AXM30/5600KS3GD</b>	<b>AXM30/5610KS3GD</b>



**ANALOGUE LINEAR OUTPUT 4 ÷ 20 mA •  
ATEX certified II 1GD for zone 0;20 •  
Cable output •**

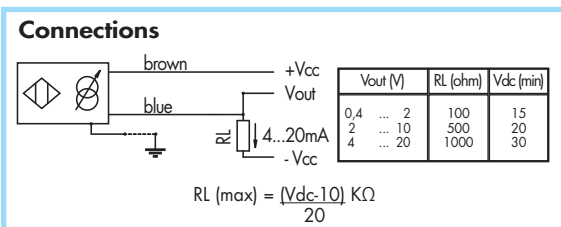
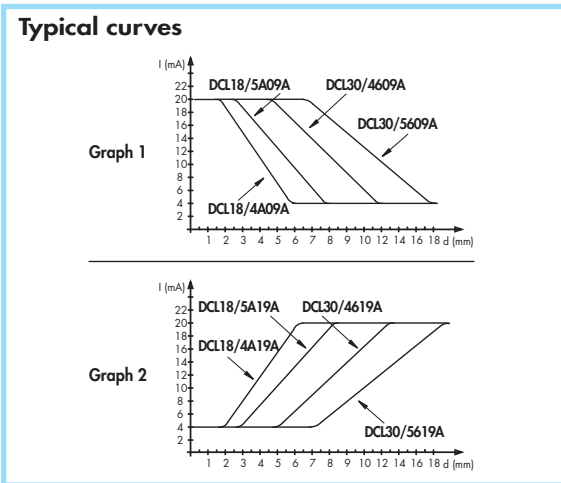
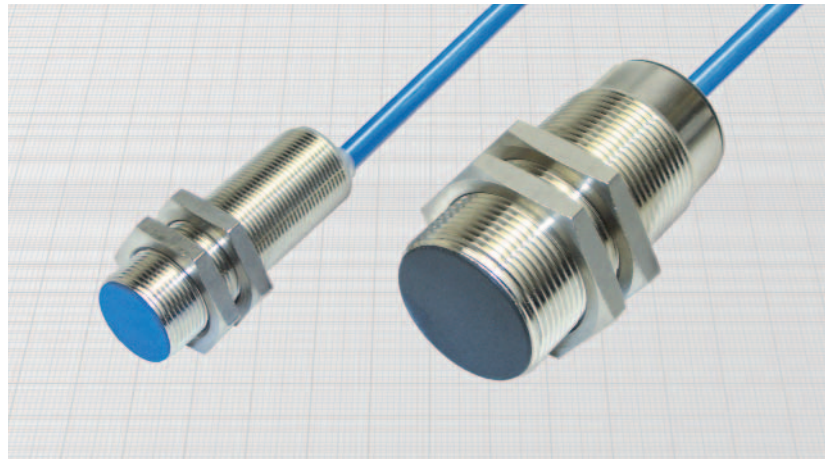
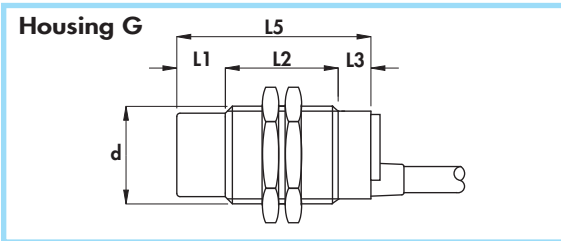
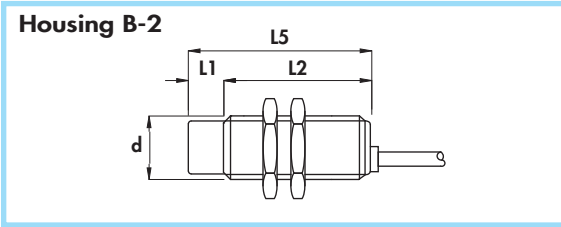

Diameter		M18 x 1	M30 x 1,5
Nut	Size	SW24	SW36
	Thickness mm	4	5
Max tightening torque Nm		35	50

- Materials:**
- Cable: 2 m PVC CEI 20 - 22 II; 90°C; 300 V; O.R.
  - Housing: nickel plated brass
  - Sensing face: plastic

**General features:**

These inductive proximity sensors provide an output current inversely or directly proportional to the distance between sensing face and metal target. The output current is dependent also on the target material. So the proximity sensors in addition to determining distance, displacements, vibrations and distortions can be used to recognize the composition of metal and alloys.

**Use of the sensor:**

The current flowing through the load RL, generates a variation in voltage across the resistor for a suitable value of RL, it is possible to obtain voltage variations from one tenth to 20 V as can be seen in the tables.

**Technical data:**

- Supply voltage: 10 ÷ 30 Vdc
- Max ripple: 20%
- Output current range: 4 ÷ 20 mA
- Temperature range: - 10° ÷ + 60°C
- Max thermal drift: < 10%
- Degree of protection: IP67
- Cable conductor cross section: 0,75 mm<sup>2</sup>
- Marking: II 1D Ex iaD 20 T80° C  
II 1G Ex ia IIC T6
- Certified IMQ 08 ATEX 010
- Protected against short-circuit and overload
- Protected against any wrong connection
- Electromagnetic compatibility (EMC) according to EN60947-5-2
- According to: EN60947-5-7/EN60079-0/EN60079-11/EN60079-26
- Shock and vibration resistance according to EN60068-2-27/EN60068-2-6

**Safety parameters:**

- Vi max: 30 V
- Ii max: 100 mA
- Ci max: 5 nF
- Li max: 750 µH
- Pi max: 660 mW

**These sensors must be used in conjunction with associated apparatus (See Sect. E)**

**Use in hazardous area according to instruction manuals**

Housing	Flush mounting Non flush mounting	L1	L2	L3	L4	L5	Cable diameter	Body diameter (d)	Maximum linearity error	No-load supply current	Max switching frequency (f)	Repeat accuracy (R)	Measurement range	ORDERING REFERENCES	
														INVERSELY PROPORTIONAL Graph 1	DIRECTLY PROPORTIONAL Graph 2
														mm	mm
B-2	•	-	50	-	-	50	5	M18 x 1	3	4	250	0,5	2 ÷ 6	DCL18/4A09A	DCL18/4A19A
B-2	•	10	40	-	-	50	5	M18 x 1	3	4	250	0,5	3 ÷ 8	DCL18/5A09A	DCL18/5A19A
G	•	-	50	10	-	60	5	M30 x 1,5	5	4	250	0,5	5 ÷ 12	DCL30/4609A	DCL30/4619A
G	•	15	35	10	-	60	5	M30 x 1,5	5	4	250	0,5	7 ÷ 18	DCL30/5609A	DCL30/5619A

# CYLINDRICAL INDUCTIVE ATEX SENSORS IN METAL HOUSING

- ANALOGUE LINEAR OUTPUT  $4 \div 20$  mA
- ATEX certified II 1GD for zone 0;20
- Connector output

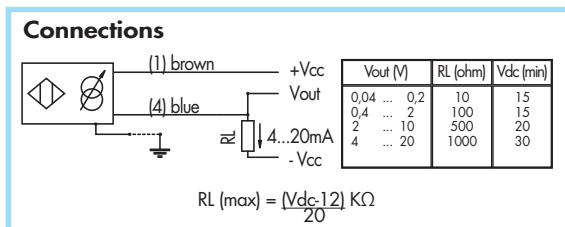
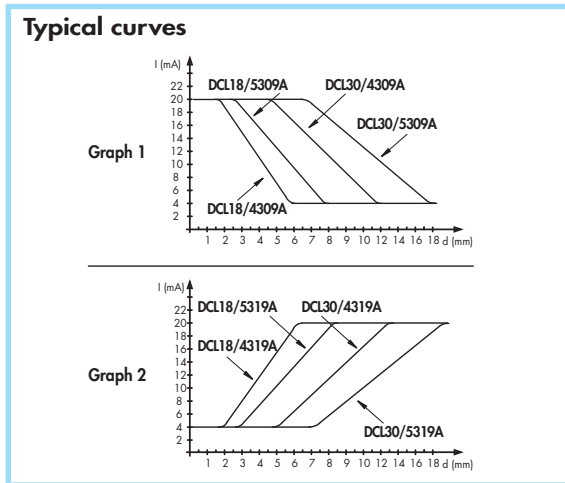
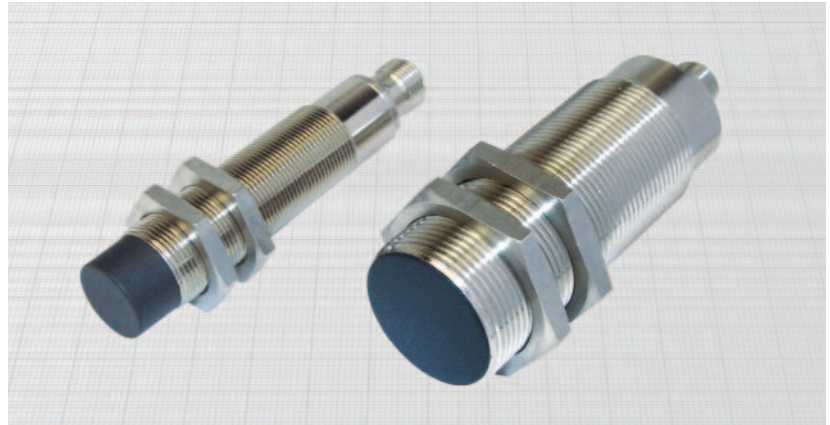
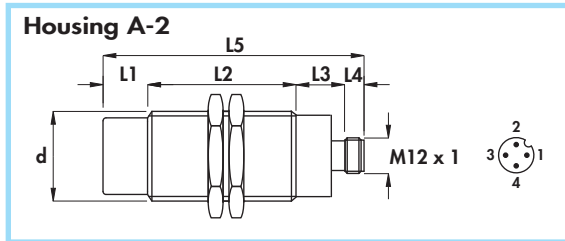
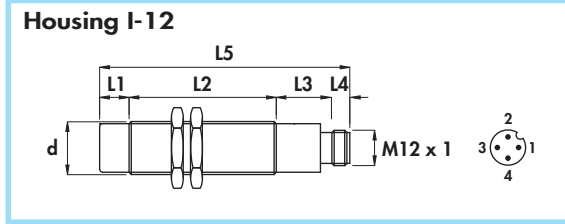

Diameter		M18 x 1	M30 x 1,5
Nut	Size	SW24	SW36
	Thickness mm	4	5
Max tightening torque Nm		35	50

**Materials:**

- Housing: nickel plated brass
- Sensing face: plastic

**General features:**

These inductive proximity sensors provide an output current inversely or directly proportional to the distance between sensing face and metal target. The output current is dependent also on the target material. So the proximity sensors in addition to determining distance, displacements, vibrations and distortions can be used to recognize the composition of metal and alloys. It is recommended to use ATEX certified connectors type C8B/002...A or C10/002...A.

**Use of the sensor:**

The current flowing through the load RL, generates a variation in voltage across the resistor for a suitable value of RL, it is possible to obtain voltage variations from one tenth to 20 V as can be seen in the tables.

**Technical data:**

- Supply voltage: 15 ÷ 30 Vdc
- Max ripple: 20%
- Output current range: 4 ÷ 20 mA
- Temperature range: -10° ÷ +60°C
- Max thermal drift: < 10%
- Degree of protection: IP67
- Marking: II 1D Ex iaD 20 T80° C  
II 1G Ex ia IIC T6

- Certified IMQ 08 ATEX 010
- Protected against short-circuit and overload
- Protected against any wrong connection
- Electromagnetic compatibility (EMC) according to EN60947-5-2
- According to: EN60947-5-7/EN60079-0/EN60079-11/EN60079-26
- Shock and vibration resistance according to IEN60068-2-27/EN60068-2-6

**Safety parameters:**

- Vi max: 30 V
- Ii max: 100 mA
- Ci max: 5 nF
- Li max: 750 µH
- Pi max: 660 mW

**These sensors must be used in conjunction with associated apparatus (See Sect. E)**

**Use in hazardous area according to instruction manuals**

Housing	Flush mounting Non flush mounting	L1	L2	L3	L4	L5	Female connector (see page G - I)	Body diameter (d)	Maximum linearity error	No. load supply current	Max switching frequency (F)	Repeat accuracy (R)	Measurement range	ORDERING REFERENCES	
														INVERSELY PROPORTIONAL Graph 1	DIRECTLY PROPORTIONAL Graph 2
														mm	mm
I-12	•	-	50	19	8	77	8B-10	M18 x 1	3	4	250	0,5	2 ÷ 6	DCL18/4309A	DCL18/4319A
I-12	•	10	50	19	8	87	8B-10	M18 x 1	3	4	250	0,5	3 ÷ 8	DCL18/5309A	DCL18/5319A
A-2	•	-	65	17	8	87	8B-10	M30 x 1,5	5	4	250	0,5	5 ÷ 12	DCL30/4309A	DCL30/4319A
A-2	•	15	50	17	8	90	8B-10	M30 x 1,5	5	4	250	0,5	7 ÷ 18	DCL30/5309A	DCL30/5319A



**NAMUR SERIES WITH LED diameter 8 mm •  
ATEX certified II 1GD for zone 0;20 •  
Cable output •**

Housing B-14

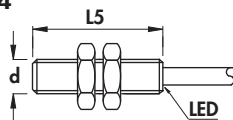

Diameter	M8 x 1	
Nut	Size	SW13
	Thickness mm	4
Max tightening torque Nm	1	

**Materials:**

- Cable: 2 m PVC CEI 20 - 22 II; 90°C; 300 V; O.R.
- Housing: plastic
- Nuts: nickel plated brass

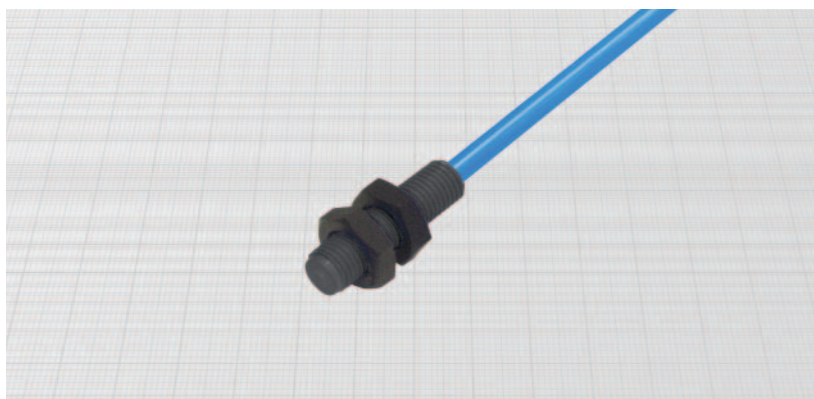

**General features:**

With this new series of sensors it's possible to drive specific inputs for NAMUR sensors or inputs for 2 wires amplified switches with low current (up to 10 mA). The load can be applied on both terminals (function PNP or NPN). The output is internally triggered and monitored by LED. The special material of the housing allows the use without additional protections against electrostatic charges.

**Technical data:**

- Working voltage: 7,7 ÷ 9 Vdc
- Max ripple: 10%
- Off-state current (I<sub>o</sub>): ≤ 1 mA
- Minimum operational current (I<sub>m</sub>): 2 mA
- Rated operational current (I<sub>g</sub>): 10 mA
- Voltage drop (U<sub>d</sub>) with load 10 mA: < 6,5 V
- Voltage drop (U<sub>d</sub>) with load 8 mA: < 5 V
- Temperature range: - 20° ÷ +60°C
- Max thermal drift of sensing distance S<sub>r</sub>: ± 10%
- Repeat accuracy (R): 2%
- Switching hysteresis max (H): 10%
- Degree of protection: IP67
- Switch status indicator: yellow LED
- Cable conductor cross section: 0,35 mm<sup>2</sup>
- Marking: II 1D Ex iaD 20 T80° C  
II 1G Ex ia IIC T6

- Certified IMQ 08 ATEX 011 X
- Electromagnetic compatibility (EMC) according to EN60947-5-2
- According to: EN60947-5-6/EN60079-0/EN60079-11/EN60079-26
- Shock and vibration resistance according to EN60068-2-27/EN60068-2-6

**Safety parameters:**

- V<sub>i</sub> max: 13,5 V
- I<sub>i</sub> max: 60 mA
- C<sub>i</sub> max: 100 nF
- L<sub>i</sub> max: 100 µH
- P<sub>i</sub> max: 200 mW

**These sensors must be used in conjunction with associated apparatus (See Sect. E)**

**Use in hazardous area according to instruction manuals**

(\* ) Note: For non flush mounting version, it's recommended to leave the sensing face outside of metal for a length equal to a half of the external diameter.

Housing	Flush mounting Non flush mounting (*)	L1	L2	L3	L4	L5	Cable diameter	Body diameter (d)	Max switching frequency (f)	Nominal sensing distance (S <sub>n</sub> ) ± 10%	ORDERING REFERENCES	
		mm	mm	mm	mm	mm						
B-14	•	-	-	-	-	30	4	M8 x 1	3	1,5	<b>DC8P/4600SA</b>	<b>DC8P/4610SA</b>
B-14	•	-	-	-	-	30	4	M8 x 1	2	2,5	<b>DC8P/5600SA</b>	<b>DC8P/5610SA</b>

# CYLINDRICAL INDUCTIVE ATEX SENSORS IN PLASTIC HOUSING

- NAMUR SERIES WITH LED diameters 12 - 18 - 30 mm
- ATEX certified II 1GD for zone 0;20
- Cable output

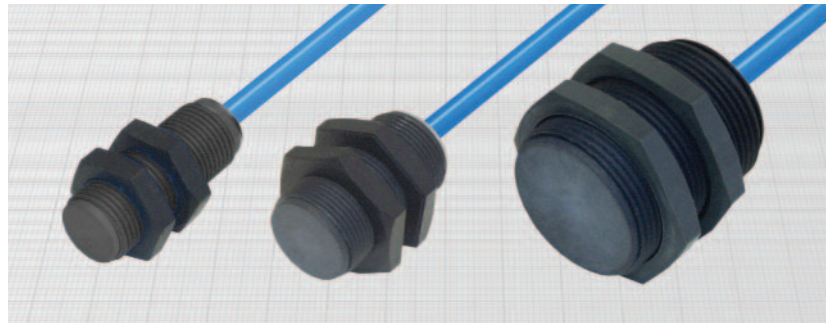
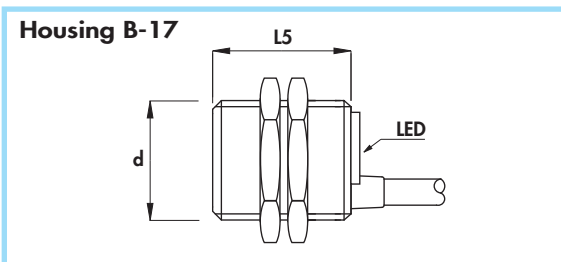
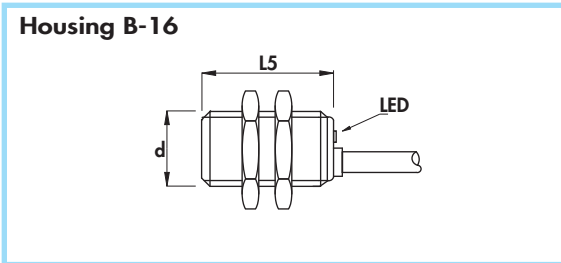
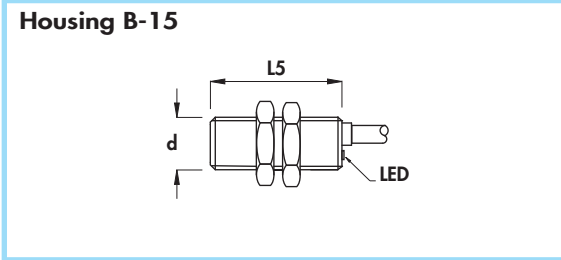

### General features:

With this new series of sensors it's possible to drive specific inputs for NAMUR sensors or inputs for 2 wires amplified switches with low current (up to 10 mA). The load can be applied on both terminals (function PNP or NPN). The output is internally triggered and monitored by LED. The special material of the housing allows the use without additional protections against electrostatic charges.

### Technical data:

- Working voltage: 7,7 ÷ 9 Vdc
- Max ripple: 10%
- Off-state current (I<sub>o</sub>): ≤ 1 mA
- Minimum operational current (I<sub>m</sub>): 2 mA
- Rated operational current (I<sub>p</sub>): 10 mA
- Voltage drop (U<sub>d</sub>) with load 10 mA: < 6,5 V
- Voltage drop (U<sub>d</sub>) with load 8 mA: < 5 V
- Temperature range: -20° ÷ +60°C
- Max thermal drift of sensing distance S<sub>p</sub>: ± 10%
- Repeat accuracy (R): 2%
- Switching hysteresis max (H): 10%
- Degree of protection: IP67
- Switch status indicator: yellow LED
- Cable conductor cross section: 0,35 mm<sup>2</sup> in diameter 12 mm  
0,75 mm<sup>2</sup> in diameters 18 and 30 mm

- Marking: II 1D Ex iaD 20 T80°C  
II 1G Ex ia IIC T6

- Certified IMQ 08 ATEX 010
- Protected against short-circuit and overload
- Protected against any wrong connection
- Electromagnetic compatibility (EMC) according to EN60947-5-2
- According to: EN60947-5-6/EN60079-0/EN60079-11/EN60079-26
- Shock and vibration resistance according to EN60068-2-27/EN60068-2-6

Diameter	M12 x 1	M18 x 1	M30 x 1,5
Nut	Size SW17	SW24	SW36
	Thickness mm 4	4	5
Max tightening torque Nm	1	4	20

### Materials:

- Cable: 2 m PVC CEI 20 - 22 II; 90°C; 300 V; O.R.
- Housing: plastic
- Nuts: nickel plated brass

### Safety parameters:

- V<sub>i</sub> max: 13,5 V
- I<sub>i</sub> max: 60 mA
- C<sub>i</sub> max: 100 nF
- L<sub>i</sub> max: 100 µH
- P<sub>i</sub> max: 200 mW

**These sensors must be used in conjunction with associated apparatus (See Sect. E)**

**Use in hazardous area according to instruction manuals**

(\*) Note: For non flush mounting version, it's recommended to leave the sensing face outside of metal for a length equal to a half of the external diameter.

Housing	Flush mounting Non flush mounting (*)	L1	L2	L3	L4	L5	Cable diameter	Body diameter (d)	Max switching frequency (f)	Nominal sensing distance (S <sub>n</sub> ) ± 10%	ORDERING REFERENCES	
		mm	mm	mm	mm	mm						
B-15	•	-	-	-	-	30	4	M12 x 1	2	2	DC12P/4600KSA	DC12P/4610KSA
B-15	•	-	-	-	-	30	4	M12 x 1	1	4	DC12P/5600KSA	DC12P/5610KSA
B-16	•	-	-	-	-	30	5	M18 x 1	0,8	5	DC18P/4600KSA	DC18P/4610KSA
B-16	•	-	-	-	-	30	5	M18 x 1	0,6	8	DC18P/5600KSA	DC18P/5610KSA
B-17	•	-	-	-	-	35	5	M30 x 1,5	0,8	10	DC30P/4600KSA	DC30P/4610KSA
B-17	•	-	-	-	-	35	5	M30 x 1,5	0,4	15	DC30P/5600KSA	DC30P/5610KSA



**NAMUR SERIES - TYPE Z •**  
**ATEX certified II 1GD for zone 0;20 •**  
**Cable output •**

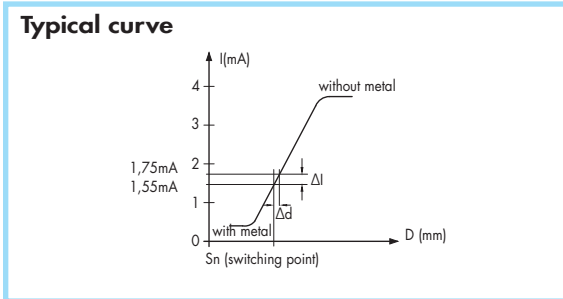
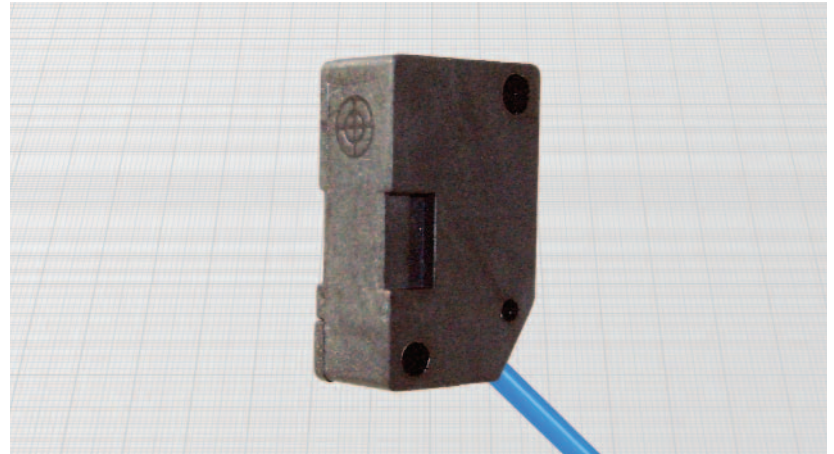
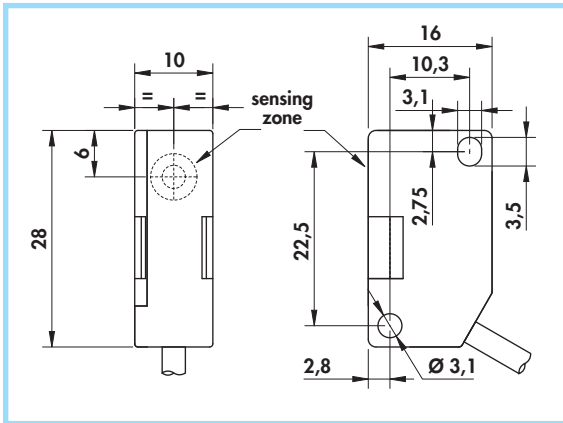

Model	Type Z
Max tightening torque Nm	1,5

**Materials:**

- Cable: 2 m PVC CEI 20 - 22 II; 90°C; 300 V; O.R.
- Housing: plastic

**General features:**

This sensor has the same shape and holes position as a type V3 microswitch. The cable position allows the mounting on every side of the housing. The special material of the housing allows the use without additional protections against electrostatic charges.

**Technical data:**

- Supply voltage according NAMUR: 7,7 ÷ 9 Vdc
- Max ripple: 10%
- Consumption at 8,2 V with Rx = 1000 Ω
  - with metal: ≤ 1 mA
  - without metal: ≥ 3 mA
- Temperature range: -20° ÷ +60°C
- Max thermal drift of sensing distance S<sub>n</sub>: ± 10%
- Repeat accuracy (R): 2%
- Degree of protection according EN60529: IP67
- Cable conductor cross section: 0,15 mm<sup>2</sup>
- Marking: II 1D Ex iaD 20 T80° C  
II 1G Ex ia IIC T6
- Certified IMQ 08 ATEX 010
- Electromagnetic compatibility (EMC) according to EN60947-5-2
- According to: EN60947-5-6/EN60079-0/EN60079-11/EN60079-26
- Shock and vibration resistance according to EN60068-2-27/EN60068-2-6

**Safety parameters:**

- V<sub>i</sub> max: 13,5 V
- I<sub>i</sub> max: 60 mA
- C<sub>i</sub> max: 100 nF
- L<sub>i</sub> max: 100 µH
- P<sub>i</sub> max: 200 mW

**These sensors must be used in conjunction with associated apparatus (See Sect. E)**

**Use in hazardous area according to instruction manuals**

(\* ) Note: See mounting precautions at page 22 of BDC General Catalogue or at this URL: <http://www.bdcelectronic.com/eng/pdfeng/022-024.pdf>

Flush mounting Non flush mounting	Cable diameter	Sensing zone diameter	Max switching frequency (f)	Nominal sensing distance (S <sub>n</sub> ) ± 10%	ORDERING REFERENCES
	mm	mm	KHz	mm	
•	3	9	1	2	<b>DCZ/4600A</b>
•	3	9	0,8	4	<b>DCZ/5600A</b>

# RECTANGULAR INDUCTIVE ATEX SENSORS

- **NAMUR SERIES - TYPE T**
- **ATEX certified II 1GD for zone 0;20**
- Cable output

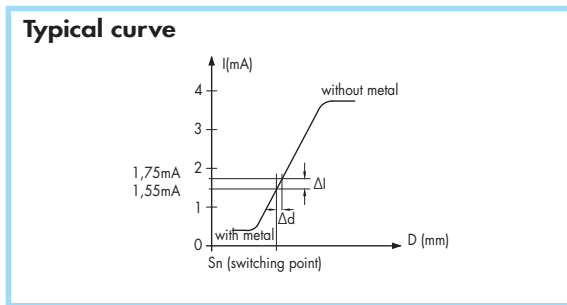
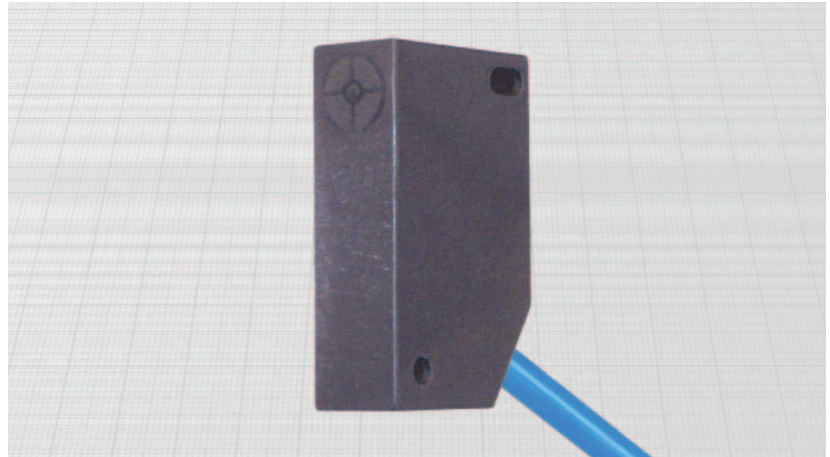
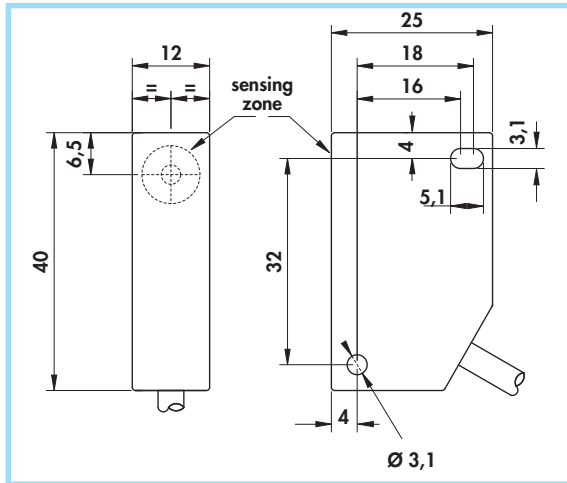

Model	Type T
Max tightening torque Nm	1

**Materials:**

- Cable: 2 m PVC CEI 20 - 22 II; 90°C; 300 V; O.R.
- Housing: plastic

**General features:**

These sensors are suitable for reduced mounting spaces. The special material of the housing allows the use without additional protections against electrostatic charges.

**Technical data:**

- Supply voltage according NAMUR: 7,7 ÷ 9 Vdc
- Max ripple: 10%
- Consumption at 8,2 V with Rx = 1000 Ω
  - with metal: ≤ 1 mA
  - without metal: ≥ 3 mA
- Temperature range: -20° ÷ + 60°C
- Max thermal drift of sensing distance S<sub>n</sub>: ± 10%
- Repeat accuracy (R): 2%
- Degree of protection according EN60529: IP67
- Cable conductor cross section: 0,35 mm<sup>2</sup>
- Marking: II 1D Ex iaD 20 T80°C  
II 1G Ex ia IIC T6
- Certified IMQ 08 ATEX 010
- Electromagnetic compatibility (EMC) according to EN60947-5-2
- According to: EN60947-5-6/EN60079-0/EN60079-11/EN60079-26
- Shock and vibration resistance according to EN60068-2-27/EN60068-2-6

**Safety parameters:**

- Vi max: 13,5 V
- Ii max: 60 mA
- Ci max: 100 nF
- Li max: 100 µH
- Pi max: 200 mW

**These sensors must be used in conjunction with associated apparatus (See Sect. E)**

**Use in hazardous area according to instruction manuals**

(\*) Note: See mounting precautions at page 22 of BDC General Catalogue or at this URL: <http://www.bdcelectronic.com/eng/pdfeng/022-024.pdf>

Flush mounting Non flush mounting	Cable diameter	Sensing zone diameter	Max switching frequency (f)	Nominal sensing distance (S <sub>n</sub> ) ± 10%	ORDERING REFERENCES
	mm	mm	KHz	mm	
•	4	9	1	2	<b>DCT/4700A</b>
•	4	9	0,8	4	<b>DCT/5700A</b>



**NAMUR SERIES - TYPE X and Y •**  
**ATEX certified II 1GD for zone 0;20 •**  
**Cable output •**

**Housing N**

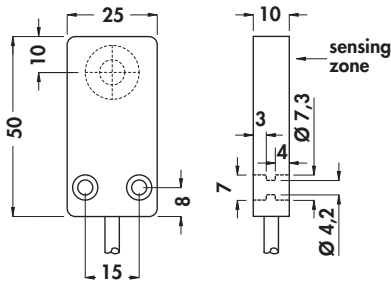

**Housing N-2**

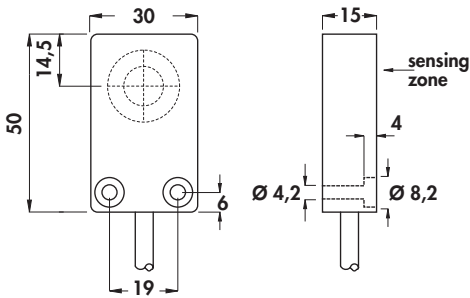

**Typical curve**

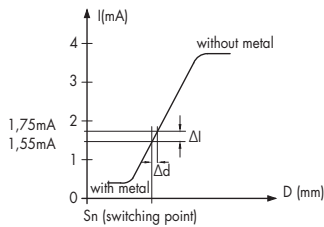

Model	Type X	Type Y
Max tightening torque Nm	1	2,5

**Materials:**

- Cable: 2 m PVC CEI 20 - 22 II; 90°C; 300 V; O.R.
- Housing: plastic

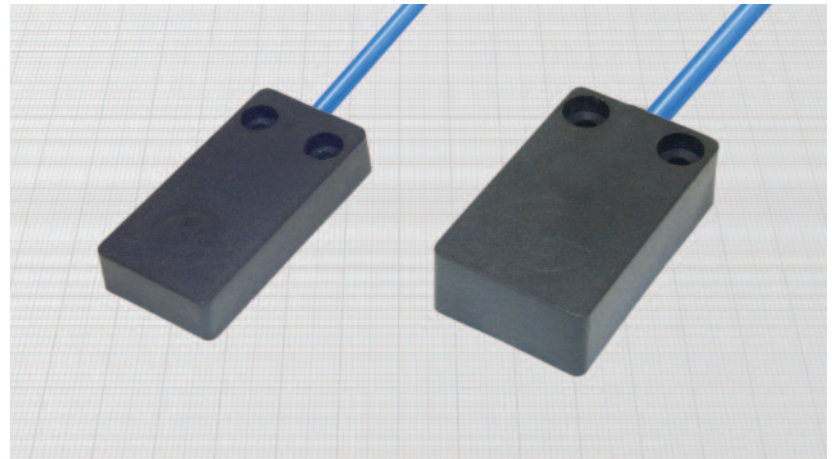

**General features:**

These sensors are suitable for reduced mounting spaces. The special material of the housing allows the use without additional protections against electrostatic charges.

**Technical data:**

- Supply voltage according NAMUR: 7,7 ÷ 9 Vdc
- Max ripple: 10%
- Consumption at 8,2 V with  $R_x = 1000 \Omega$ 
  - with metal:  $\leq 1 \text{ mA}$
  - without metal:  $\geq 3 \text{ mA}$
- Temperature range:  $-20^\circ \div +60^\circ \text{C}$
- Max thermal drift of sensing distance  $S_n$ :  $\pm 10\%$
- Repeat accuracy (R): 2%
- Degree of protection according EN60529: IP67
- Cable conductor cross section: 0,75 mm<sup>2</sup>
- Marking: II 1D Ex iaD 20 T80°C  
II 1G Ex ia IIC T6
- Certified IMQ 08 ATEX 010
- Electromagnetic compatibility (EMC) according to EN60947-5-2
- According to: EN60947-5-6/EN60079-0/EN60079-11/EN60079-26
- Shock and vibration resistance according to EN60068-2-27/EN60068-2-6

**Safety parameters:**

- $V_i$  max: 13,5 V
- $I_i$  max: 60 mA
- $C_i$  max: 100 nF
- $L_i$  max: 100  $\mu\text{H}$
- $P_i$  max: 200 mW

**These sensors must be used in conjunction with associated apparatus (See Sect. E)**

**Use in hazardous area according to instruction manuals**

(\*) Note: See mounting precautions at page 22 of BDC General Catalogue or at this URL:  
<http://www.bdcelectronic.com/eng/pdfeng/022-024.pdf>

Housing	Flush mounting Non flush mounting	Cable diameter	Sensing zone diameter	Max switching frequency (f)	Nominal sensing distance (S <sub>n</sub> ) ± 10%	ORDERING REFERENCES
		mm	mm	KHz	mm	
Z	•	5	15	2	5	DCX/4700A DCX/5700A
		5	15	1	8	
N-2	•	5	23	0,8	10	DCY/4700A DCY/5700A
		5	23	0,4	15	

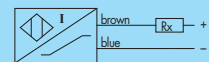



# RECTANGULAR INDUCTIVE ATEX SENSORS

- **NAMUR SERIES - TYPE P - 5 Position head**
- **ATEX certified II 1G for zone 0**
- Terminal block output

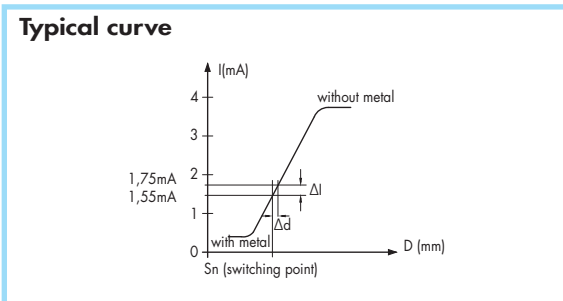
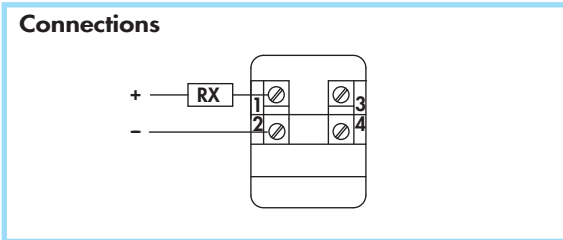
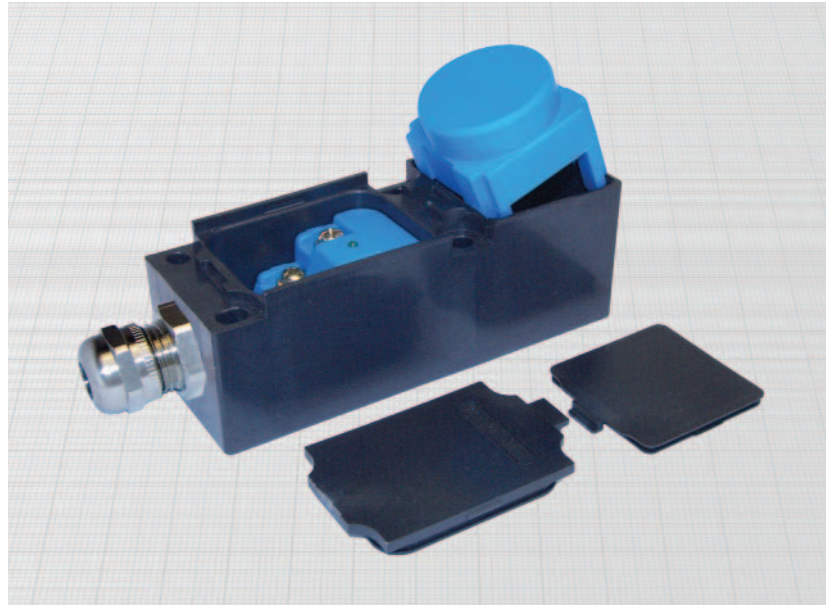
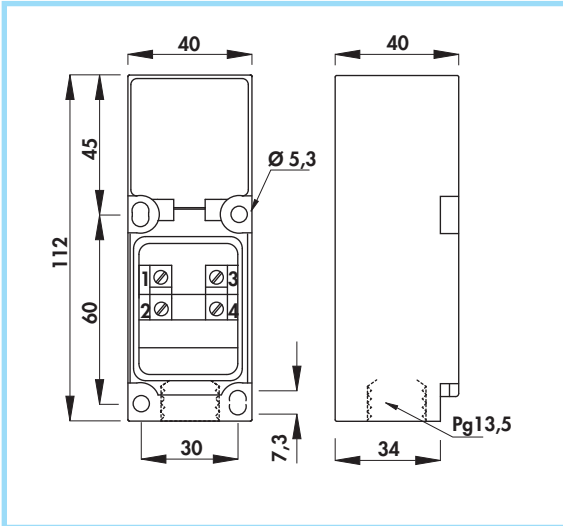

Model	Type P
Max tightening torque Nm	4
Cable gland clamping range (mm)	5 ÷ 12

**Materials:**

- Housing: plastic
- Cable gland: nickel plated brass

**General features:**

These sensors are described as “revolving head” because the actual sensor head, inside the plastic body, can be arranged in 5 different positions. To choose the desired direction it is sufficient to remove the cover, remove the head and positioning it according to the user’s particular requirements. The internal terminal block can be reached easily by removing the front cover. The particular plastic material allows the use without additional protections against electrostatic charges.

**Technical data:**

- Supply voltage according NAMUR: 7,7 ÷ 9 Vdc
- Max ripple: 10%
- Consumption at 8,2 V with Rx = 1000 Ω
  - with metal: ≤ 1 mA
  - without metal: ≥ 3 mA
- Temperature range: - 20° ÷ + 60°C
- Max thermal drift of sensing distance S<sub>n</sub>: ± 10%
- Repeat accuracy (R): 2%
- Degree of protection according EN60529 (with fully locked gland): IP65
- Marking: II 1G Ex ia IIC T6

- Certified IMQ 08 ATEX 010
- Electromagnetic compatibility (EMC) according to EN60947-5-2
- According to: EN60947-5-6/EN60079-0/EN60079-11/EN60079-26
- Shock and vibration resistance according to EN60068-2-27/EN60068-2-6

**Safety parameters:**

- Vi max: 13,5 V
- Ii max: 60 mA
- Ci max: 100 nF
- Li max: 100 μH
- Pi max: 200 mW

**These sensors must be used in conjunction with associated apparatus (See Sect. E)**

**Use in hazardous area according to instruction manuals**

Flush mounting Non flush mounting	Revolving head diameter	Max switching frequency (f)	Nominal sensing distance (S <sub>n</sub> ) ± 10%	ORDERING REFERENCES
	mm	KHz	mm	
•	35	0,2	15	<b>DCP/4700A</b>
•	35	0,2	20	<b>DCP/5700A</b>



**NAMUR SERIES - diameter 80 mm •  
ATEX certified II 1GD for zone 0;20 •  
Cable and connector output •**

**Housing P**

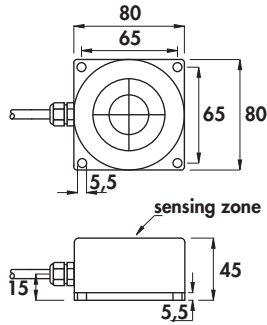

**Housing P-1**

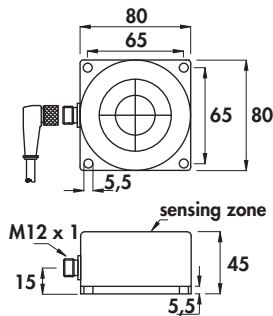

**Typical curve**

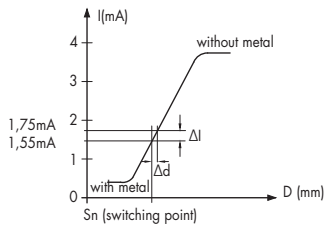

Model	Type DC80...
Max tightening torque Nm	5

**Materials:**

- Cable: 2 m PVC CEI 20 - 22 II; 90°C; 300 V; O.R.
- Housing: plastic

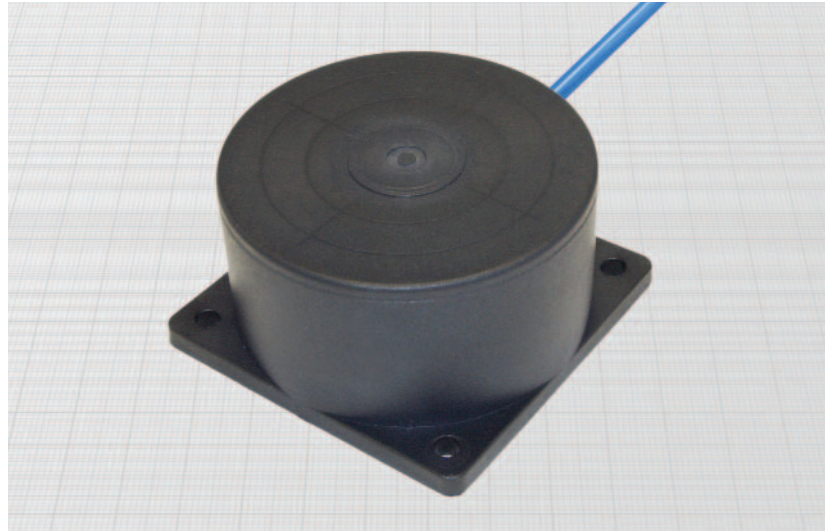

**General features:**

Suitable for detection of large targets. The special material of the housing allows the use without additional protections against electrostatic charges.

**Technical data:**

- Supply voltage according NAMUR: 7,7 ÷ 9 Vdc
- Max ripple: 10%
- Consumption at 8,2 V with  $R_x = 1000 \Omega$ 
  - with metal:  $\leq 1 \text{ mA}$
  - without metal:  $\geq 3 \text{ mA}$
- Temperature range:  $-20^\circ \div +60^\circ \text{C}$
- Max thermal drift of sensing distance  $S_r$ :  $\pm 10\%$
- Repeat accuracy (R): 2%
- Degree of protection according EN60529: IP67
- Cable conductor cross section: 0,75 mm<sup>2</sup>
- Marking: II 1D Ex iaD 20 T80° C  
II 1G Ex ia IIC T6
- Certified IMQ 08 ATEX 010
- Electromagnetic compatibility (EMC) according to EN60947-5-2
- According to: EN60947-5-6/EN60079-0/EN60079-11/EN60079-26
- Shock and vibration resistance according to EN60068-2-27/EN60068-2-6

**Safety parameters:**

- $V_i$  max: 13,5 V
- $I_i$  max: 60 mA
- $C_i$  max: 100 nF
- $L_i$  max: 100  $\mu\text{H}$
- $P_i$  max: 200 mW

**These sensors must be used in conjunction with associated apparatus (See Sect. E)**

**Use in hazardous area according to instruction manuals**

Housing	Mounting Flush mounting Non flush mounting	Cable diameter	Female connector (see page G - 1)	Body diameter (d)	Max switching frequency (f)	Nominal sensing distance (S <sub>n</sub> ) ± 10%	ORDERING REFERENCES
		mm	n°	mm	KHz	mm	
P	•	5	-	80	0,5	40	<b>DC80/5800A</b>
P-1	•	-	8B-10	80	0,5	40	<b>DC80/5300A</b>

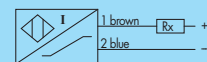

# RECTANGULAR INDUCTIVE ATEX SENSORS

- **NAMUR SERIES - TYPE R**
- **ATEX certified II 1GD for zone 0;20**
- Cable and connector output

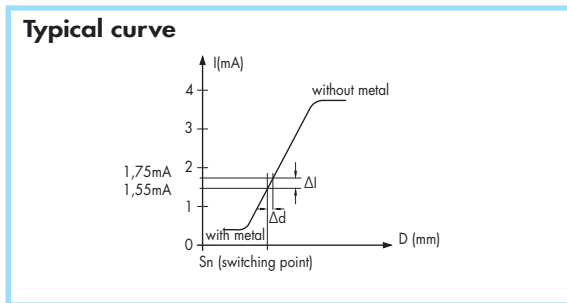
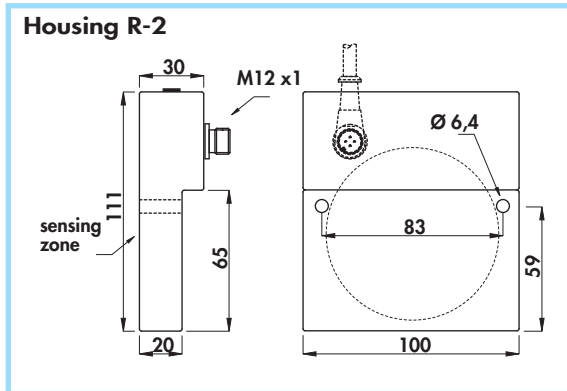
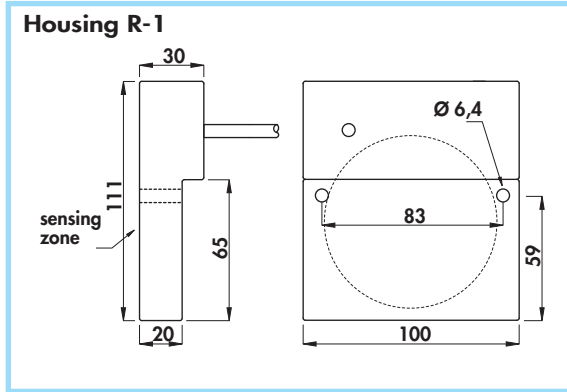

Model	Type R
Max tightening torque Nm	1,5

**Materials:**

- Cable: 2 m PVC CEI 20 - 22 II; 90°C; 300 V; O.R.
- Housing: plastic

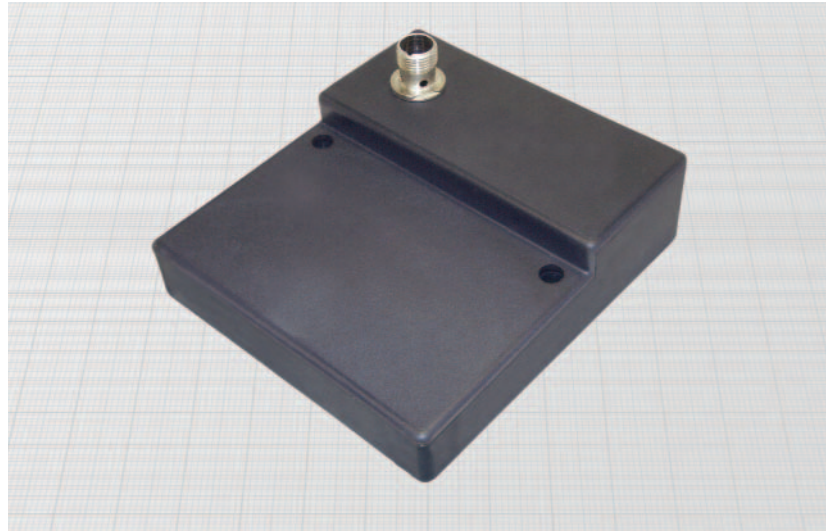

**General features:**

Suitable for detection of large targets. The special material of the housing allows the use without additional protections against electrostatic charges.

**Technical data:**

- Supply voltage according NAMUR: 7,7 ÷ 9 Vdc
- Max ripple: 10%
- Consumption at 8,2 V with Rx = 1000 Ω
  - with metal: ≤ 1 mA
  - without metal: ≥ 3 mA
- Temperature range: - 20° ÷ + 60°C
- Max thermal drift of sensing distance S<sub>i</sub>: ± 10%
- Repeat accuracy (R): 2%
- Degree of protection according EN60529: IP67
- Cable conductor cross section: 0,75 mm<sup>2</sup>
- Marking: II 1D Ex iaD 20 T80° C  
II 1G Ex ia IIC T6
- Certified IMQ 08 ATEX 010
- Electromagnetic compatibility (EMC) according to EN60947-5-2
- According to: EN60947-5-6/EN60079-0/EN60079-11/EN60079-26
- Shock and vibration resistance according to EN60068-2-27/EN60068-2-6

**Safety parameters:**

- Vi max: 13,5 V
- Ii max: 60 mA
- Ci max: 100 nF
- Li max: 100 μH
- Pi max: 200 mW

**These sensors must be used in conjunction with associated apparatus (See Sect. E)**

**Use in hazardous area according to instruction manuals**

Housing	Mounting Flush mounting Non flush mounting	Cable diameter	Female connector (see page G - 1)	Sensing zone diameter	Max switching frequency (f <sub>s</sub> )	Nominal sensing distance (S <sub>n</sub> ) ± 10%	ORDERING REFERENCES
		mm					
R - 1	•	5	-	65	0,3	55	<b>DCR/5800A</b>
R - 2	•	-	8B - 10	65	0,3	55	<b>DCR/5300A</b>

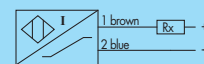



**AMPLIFIED IN d.c. 3-wire - TYPE Z •**  
**ATEX certified II 3GD for zone 2;22 •**  
 Cable output •

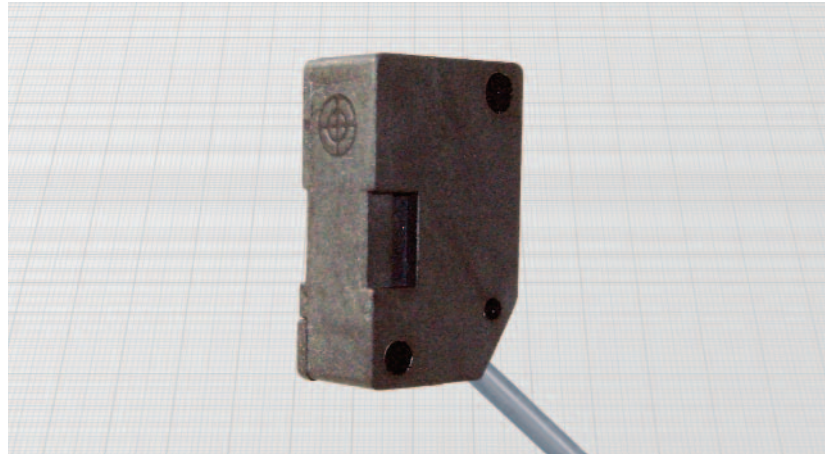
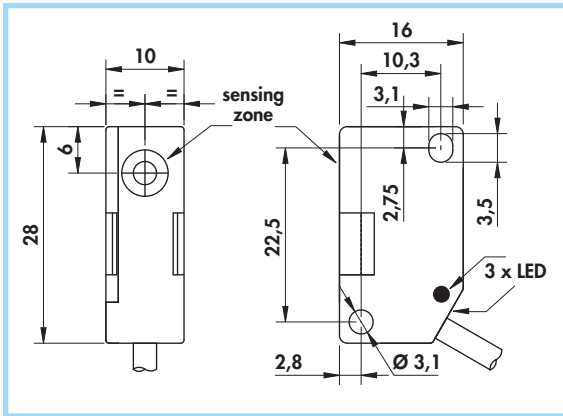

Model	Type Z
Max tightening torque Nm	1,5

**Materials:**

- Cable: 2 m PVC CEI 20 - 22 II; 90°C; 300 V; O.R.
- Housing: plastic

**General features:**

This sensor has the same shape and fixing holes as V3 standard microswitches. The particular cable position allows the mounting on every side of the housing. The special material of the housing allows the use without additional protections against electrostatic charges. The output status is indicated by LED visible from 3 sides.

**Technical data:**

- Supply voltage ( $U_B$ ): 7 ÷ 30 Vdc
- Max ripple: 10%
- No-load supply current ( $I_0$ ): ≤ 10 mA
- Voltage drop ( $U_d$ ): < 1,5 V
- Temperature range: - 25° ÷ + 60°C
- Max thermal drift of sensing distance  $S_r$ : ± 10%
- Repeat accuracy (R): 2%
- Switching hysteresis max (H): 10%
- Degree of protection: IP67
- Switch status indicator: yellow LED
- Cable conductor cross section: 0,15 mm<sup>2</sup>
- Marking: II 3D Ex tc IIIC T80°C IP67 X  
II 3G Ex nAc IIC T6 X

- Protected against short-circuit and overload
- Protected against any wrong connection
- Suppression of initial false impulse
- Electromagnetic compatibility (EMC) according to EN60947-5-2
- According to: EN60079-0/EN60079-15/EN60079-31
- Shock and vibration resistance according to EN60068-2-27/EN60068-2-6

Use in hazardous area according to instruction manuals

Flush mounting Non flush mounting	Cable diameter	Sensing zone diameter	Rated operational current ( $I_e$ )	Max switching frequency (f)	Nominal sensing distance ( $S_n$ ) ± 10%	ORDERING REFERENCES	
						PNP (positive switching)	
•	3	9	200	2	2	NO	NC
						<b>DCAZ/4609KS3GD</b>	<b>DCAZ/4619KS3GD</b>
•	3	9	200	1,5	4	<b>DCAZ/5609KS3GD</b>	<b>DCAZ/5619KS3GD</b>
						NPN (negative switching)	
						Use the above part number changing the last 9 with 8 (ie DCAZ/4608KS3GD)	
						NO	NC

(\*) Note: See mounting precautions at page 22 of BDC General Catalogue or at this URL: <http://www.bdcelectronic.com/eng/pdfeng/022-024.pdf>

# RECTANGULAR INDUCTIVE ATEX SENSORS

- **AMPLIFIED IN d.c. 3 and 4-wires - TYPE T**
- **ATEX certified II 3GD for zone 2;22**
- Cable output

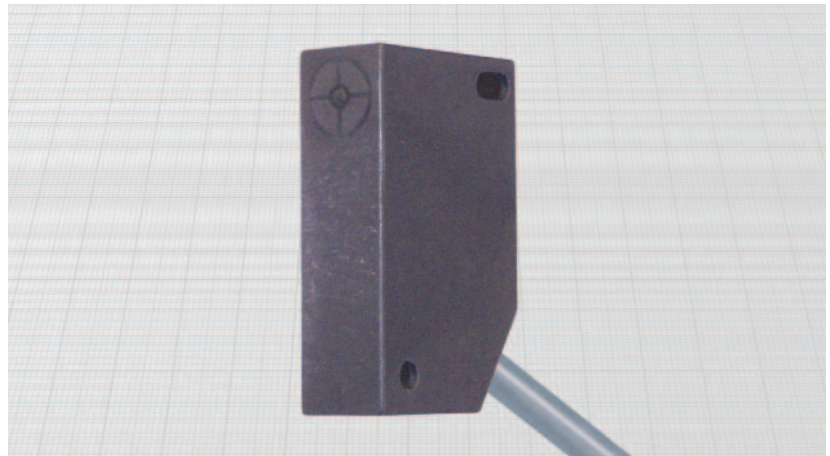
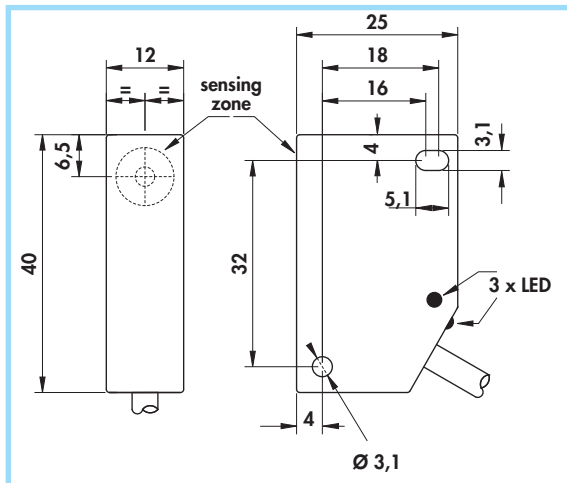

Model	Type T
Max tightening torque Nm	1

### Materials:

- Cable: 2 m PVC CEI 20 - 22 II; 90°C; 300 V; O.R.
- Housing: plastic

### General features:

These sensors are suitable for reduced mounting spaces. The special material of the housing allows the use without additional protections against electrostatic charges.

### Technical data:

- Supply voltage ( $U_b$ ): 5 ÷ 40 Vdc
- Max ripple: 10%
- No-load supply current ( $I_0$ ): ≤ 10 mA
- Voltage drop ( $U_d$ ): < 1,5 V
- Temperature range: - 25° ÷ + 60°C
- Max thermal drift of sensing distance  $S_T$ : ± 10%
- Repeat accuracy (R): 2%
- Switching hysteresis max (H): 10%
- Degree of protection: IP67
- Switch status indicator: yellow LED
- Cable conductor cross section: 0,25 mm<sup>2</sup> in 4-wire version  
0,35 mm<sup>2</sup> in 3-wire version

- Marking: II 3D Ex tc IIIC T80°C IP67 X  
II 3G Ex nAc IIC T6 X

- Protected against short-circuit and overload
- Protected against any wrong connection
- Suppression of initial false impulse
- Electromagnetic compatibility (EMC) according to EN60947-5-2
- According to: EN60079-0/EN60079-15/EN60079-31
- Shock and vibration resistance according to EN60068-2-27/EN60068-2-6

(\*) Note: See mounting precautions at page 22 of BDC General Catalogue or at this URL: <http://www.bdcelectronic.com/eng/pdfeng/022-024.pdf>

### Use in hazardous area according to instruction manuals

Flush mounting Non flush mounting	Cable diameter mm	Sensing zone diameter mm	Max switching frequency (f) KHz	Rated operational current (I <sub>o</sub> ) mA	Nominal sensing distance (S <sub>n</sub> ) ±10% mm	ORDERING REFERENCES		
						PNP (positive switching)		
•	4	9	1	200	2	NO brown black blue	NC brown black blue	NO + NC brown black white blue
	4	9	0,8	200	4	<b>DCAT/4709KS3GD</b>	<b>DCAT/4719KS3GD</b>	<b>DCAT/4729KS3GD</b>
•	4	9	0,8	200	4	<b>DCAT/5709KS3GD</b>	<b>DCAT/5719KS3GD</b>	<b>DCAT/5729KS3GD</b>
						NPN (negative switching)		
						Use the above part number changing the last 9 with 8 (ie DCAT/4708KS3GD)		
						NO brown black blue	NC brown black blue	NO + NC brown black white blue



**AMPLIFIED IN d.c. 3 and 4-wires - TYPE X and Y •  
ATEX certified II 3GD for zone 2;22 •  
Cable output •**

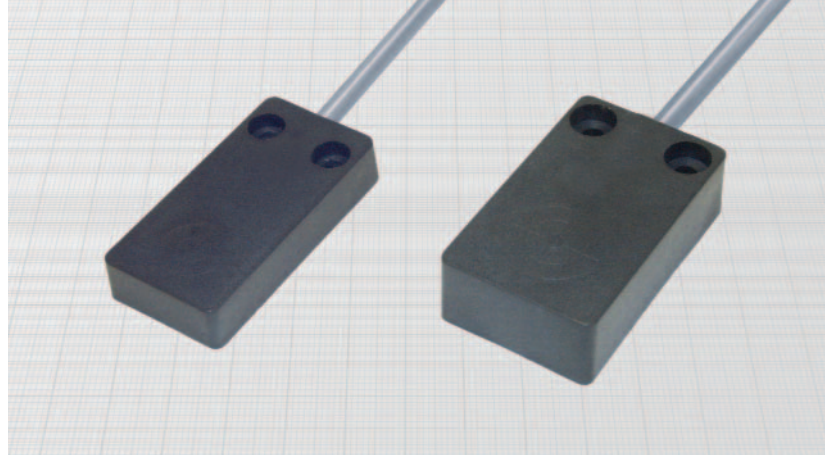
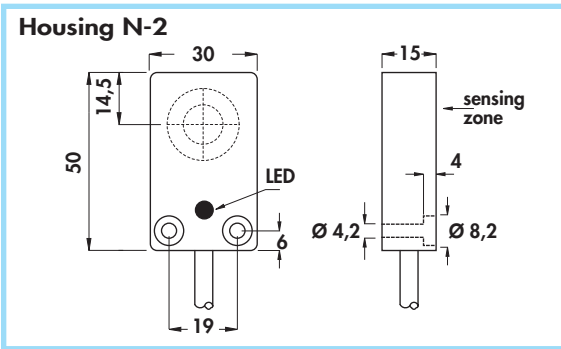
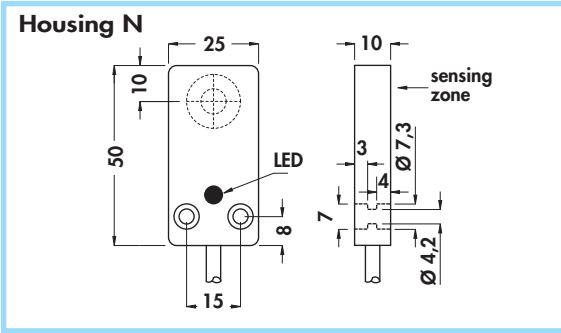

Model	Type X	Type Y
Max tightening torque Nm	1	2,5

**Materials:**

- Cable: 2 m PVC CEI 20 - 22 II; 90°C; 300 V; O.R.
- Housing: plastic

**General features:**

This series is suitable to the mounting in guideway. The flush mounting version can be placed side by side. The special material of the housing allows the use without additional protections against electrostatic charges.

**Technical data:**

- Supply voltage ( $U_B$ ): 7 ÷ 60 Vdc
- Max ripple: 10%
- No-load supply current ( $I_0$ ): ≤ 10 mA
- Voltage drop ( $U_d$ ): < 2,2 V
- Temperature range: - 25° ÷ + 60°C
- Max thermal drift of sensing distance  $S_r$ : ± 10%
- Repeat accuracy (R): 2%
- Switching hysteresis max (H): 10%
- Degree of protection: IP67
- Switch status indicator: yellow LED
- Cable conductor cross section: 0,50
- Marking: II 3D Ex tc IIIC T80°C IP67 X  
II 3G Ex nAc IIC T6 X

- Protected against short-circuit and overload
- Protected against any wrong connection
- Suppression of initial false impulse
- Electromagnetic compatibility (EMC) according to EN60947-5-2
- According to: EN60079-0/EN60079-15/EN60079-31
- Shock and vibration resistance according to EN60068-2-27/EN60068-2-6

(\*) Note: See mounting precautions at page 22 of BDC General Catalogue or at this URL: <http://www.bdcelectronic.com/eng/pdfeng/022-024.pdf>

**Use in hazardous area according to instruction manuals**

Housing	Mounting		Cable diameter	Female connector (v. page G - 1)	Sensing zone diameter	Max switching frequency (f)	Rated operational current (I <sub>e</sub> )	Nominal sensing distance (S <sub>n</sub> ) ± 10%	ORDERING REFERENCES		
	Flush mounting	Non flush mounting							PNP (positive switching)		
N	•	•	5	-	15	1	200	5			
	•	•	5	-	15	1	200	8	<b>DCAX/4609KS3GD</b>	<b>DCAX/4619KS3GD</b>	<b>DCAX/4929KS3GD</b>
N-2	•	•	5	-	23	0,8	200	10	<b>DCAY/4609KS3GD</b>	<b>DCAY/4619KS3GD</b>	<b>DCAY/4629KS3GD</b>
	•	•	5	-	23	0,4	200	15	<b>DCAY/5609KS3GD</b>	<b>DCAY/5619KS3GD</b>	<b>DCAY/5629KS3GD</b>
									NPN (negative switching)		
									Use the above part number changing the last 9 with 8 (ie DCAX/4608KS3GD)		

- **NAMUR SERIES**
- **ATEX certified II 1GD for zone 0;20**
- Cable output

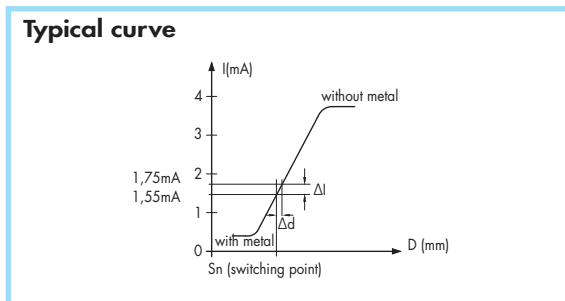
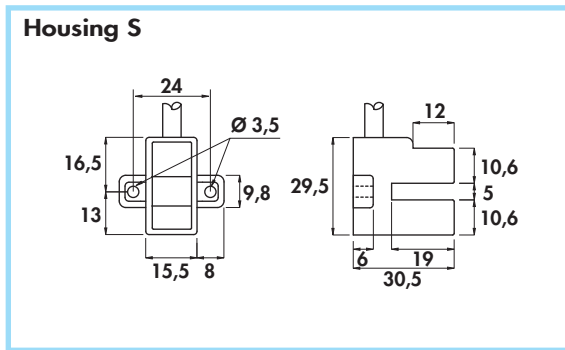
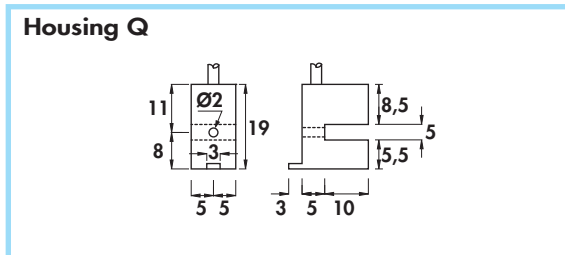
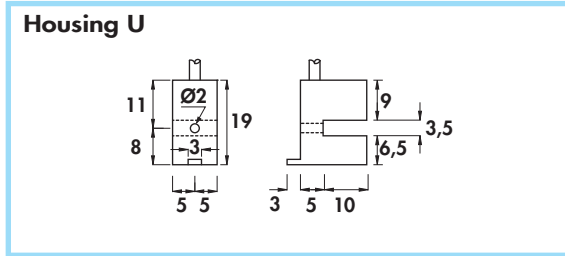

Model	Type DF3,5/...	Type DF5/...	Type DF6/...
Max tightening torque Nm	0,25	0,25	0,75

**Materials:**

- Cable: 2 m PVC CEI 20 - 22 II; 90°C; 300 V; O.R.
- Housing: plastic

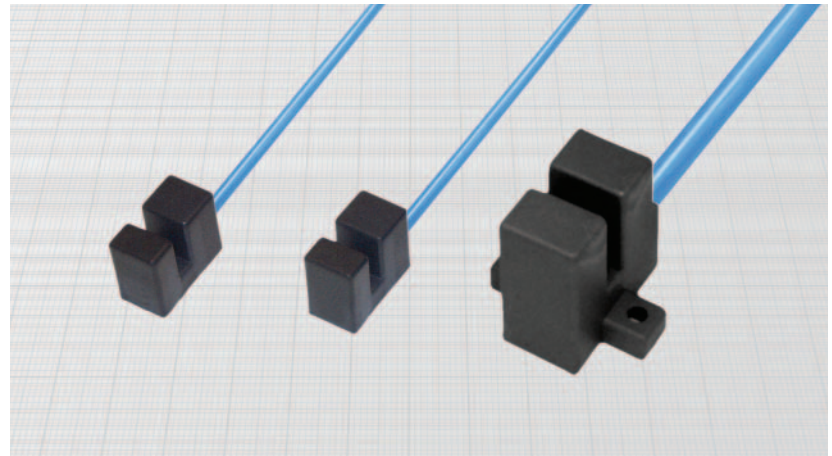

**General features:**

These sensors are able to detect the presence of a metal blade into the slot. The switching point of the output happens when about the 70% of internal faces is covered by the blade. The special material of the housing allows the use without additional protections against electrostatic charges.

**Technical data:**

- Supply voltage according NAMUR: 7,7 ÷ 9 Vdc
- Max ripple: 10%
- Consumption at 8,2 V with Rx = 1000 Ω
  - with metal: ≤ 1 mA
  - without metal: ≥ 3 mA
- Temperature range: -20° ÷ + 60°C
- Max thermal drift of sensing distance S<sub>r</sub>: ± 10%
- Repeat accuracy (R): 2%
- Degree of protection according EN60529: IP67
- Cable conductor cross section: 0,14 mm<sup>2</sup> in types DF3,5/... and DF5/...  
0,75 mm<sup>2</sup> in type DF6/...
- Marking: II 1D Ex iaD 20 T80° C  
II 1G Ex ia IIC T6
- Certified IMQ 08 ATEX 010
- Electromagnetic compatibility (EMC) according to EN60947-5-2
- According to: EN60947-5-6/EN60079-0/EN60079-11/EN60079-26
- Shock and vibration resistance according to EN60068-2-27/EN60068-2-6

**Safety parameters:**

- V<sub>i</sub> max: 13,5 V
- I<sub>i</sub> max: 60 mA
- C<sub>i</sub> max: 100 nF
- L<sub>i</sub> max: 100 µH
- P<sub>i</sub> max: 200 mW

**These sensors must be used in conjunction with associated apparatus (See Sect. E)**

**Use in hazardous area according to instruction manuals**

Housing	Cable diameter	Gap width	Max switching frequency (f)	Minimum penetration	ORDERING REFERENCES
	mm	mm	KHz	mm	
U	3	3,5	3	5	<b>DF3,5/4600A</b>
Q	3	5	3	5	<b>DF5/4600A</b>
S	5	5	1	9	<b>DF6/4600A</b>

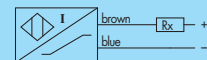



**NAMUR SERIES •**  
**ATEX certified II 1GD for zone 0;20 •**  
**Cable output •**

**Housing T**

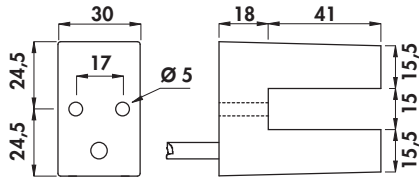

**Housing V**

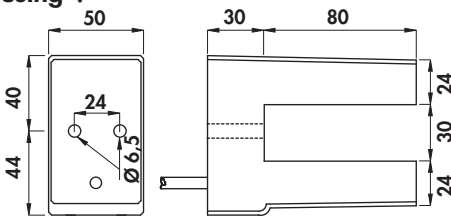

**Typical curve**

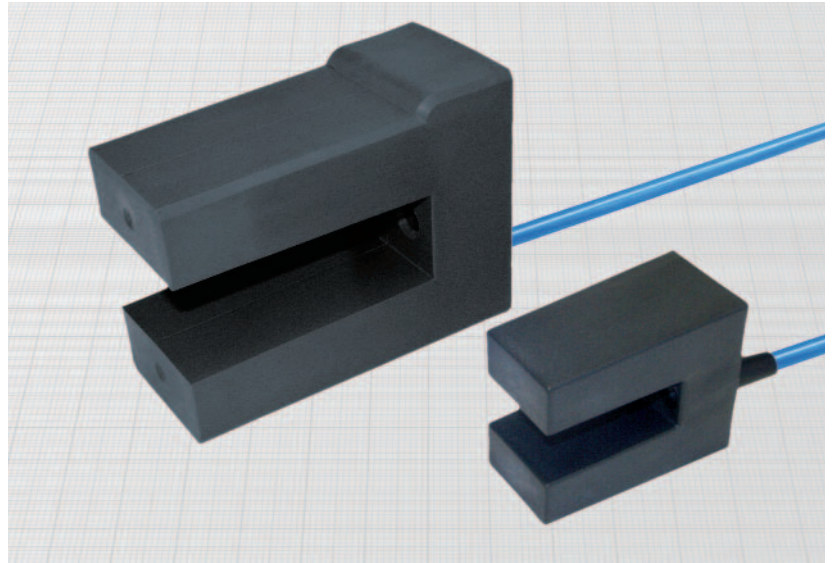
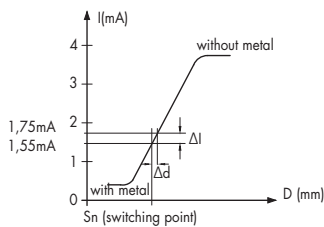

Model	Type DF15/...	Type DF30/...
Max tightening torque Nm	4	5

**Materials:**

- Cable: 2 m PVC CEI 20 - 22 II; 90°C; 300 V; O.R.
- Housing: plastic

**General features:**

These sensors are able to detect the presence of a metal blade into the slot. The switching point of the output happens when about the 70% of internal faces is covered by the blade. The special material of the housing allows the use without additional protections against electrostatic charges.

**Technical data:**

- Supply voltage according NAMUR: 7,7 ÷ 9 Vdc
- Max ripple: 10%
- Consumption at 8,2 V with Rx = 1000 Ω
  - with metal: ≤ 1 mA
  - without metal: ≥ 3 mA
- Temperature range: - 20° ÷ + 60°C
- Max thermal drift of sensing distance S<sub>i</sub>: ± 10%
- Repeat accuracy (R): 2%
- Degree of protection according EN60529: IP67
- Cable conductor cross section: 0,75 mm<sup>2</sup>
- Marking: II 1D Ex iaD 20 T80° C  
II 1G Ex ia IIC T6
- Certified IMQ 08 ATEX 010
- Electromagnetic compatibility (EMC) according to EN60947-5-2
- According to: EN60947-5-6/EN60079-0/EN60079-11/EN60079-26
- Shock and vibration resistance according to EN60068-2-27/EN60068-2-6

**Safety parameters:**

- V<sub>i</sub> max: 13,5 V
- I<sub>i</sub> max: 60 mA
- C<sub>i</sub> max: 100 nF
- L<sub>i</sub> max: 100 µH
- P<sub>i</sub> max: 200 mW

**These sensors must be used in conjunction with associated apparatus (See Sect. E)**

**Use in hazardous area according to instruction manuals**

Housing	Cable diameter mm	Gap width mm	Max switching frequency (f) KHz	Minimum penetration mm	ORDERING REFERENCES
T	5	15	0,8	16	<b>DF15/4600A</b>
V	5	30	0,3	30	<b>DF30/4600A</b>